

RAXN-LCD

Network Remote Annunciator Panel

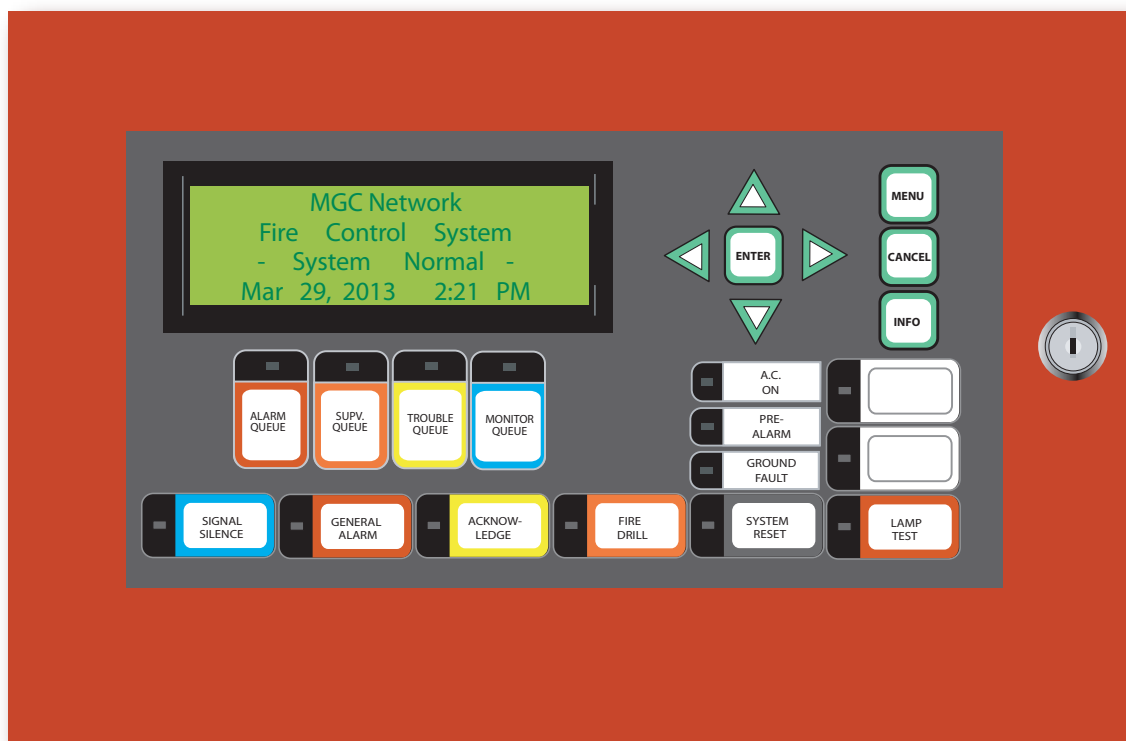
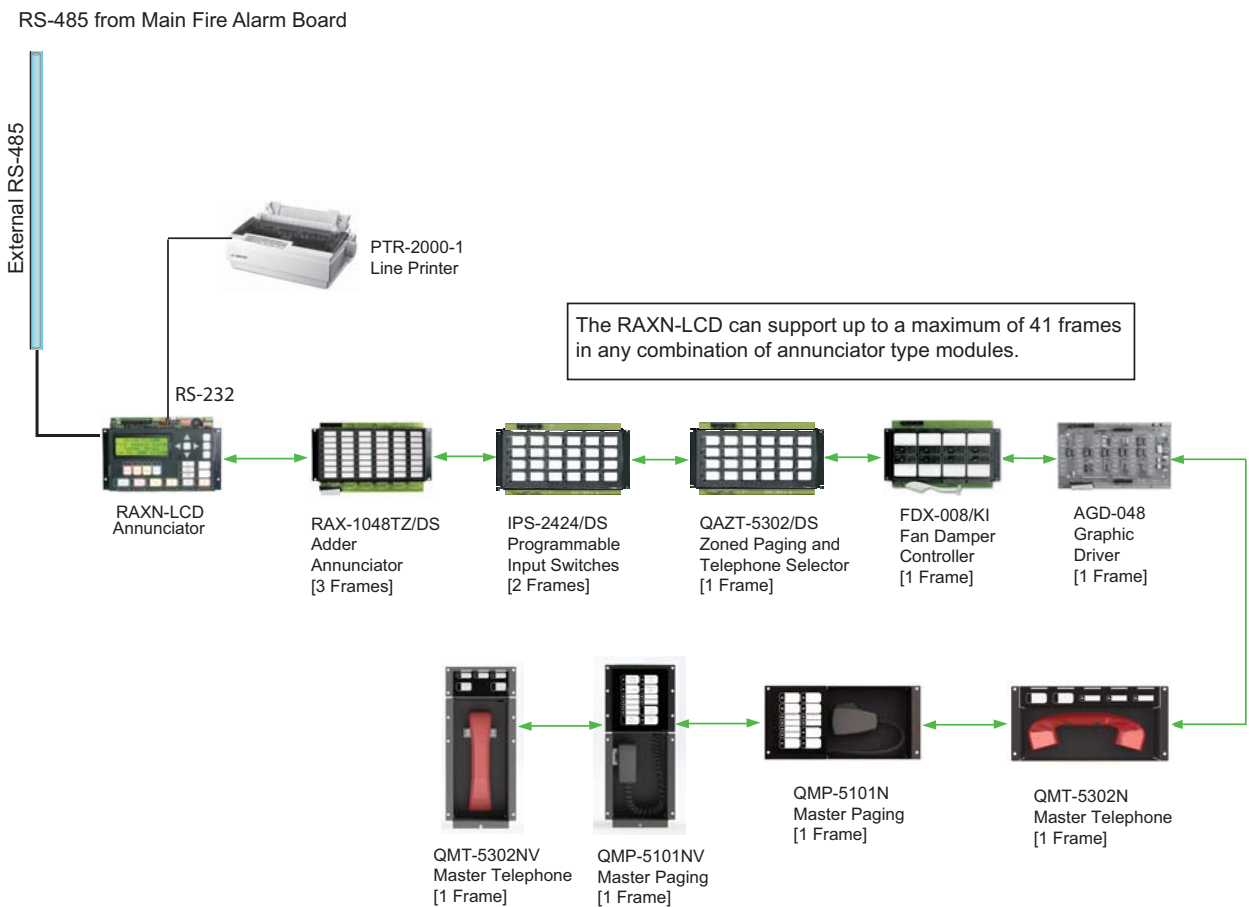

Table of Contents

1.0	Introduction	1
2.0	Installation Instructions	2
3.0	Jumper Settings	3
4.0	DIP Switch Settings	4
5.0	Wiring Instructions	5
6.0	Cable Connections	6
7.0	Specifications	7
8.0	Battery Calculations	8
9.0	Warranty & Warning Information	9

1.0 Introduction

MGC's remote shared display is the RAXN-LCD. The RAXN-LCD provides a replica of the main Fire Alarm Panel display at a remote location. It is equipped with a large 4 line x 20 character back-lit alphanumeric LCD display that uses a simple menu system complete with a directional keypad and switches for Enter, Menu, Cancel and Info. The display expands with up to a total of 41 frames made up of display adder modules and up to 7 RAXN-LCDs per node, refer to figure below. The RAXN-LCD may be mounted in the BB-1000 (MMX-BB-1000) Series backboxes, the BB-5008, BB-5014, BBX-FXMNS (MMX-BBX-FXMNS) and FX-LOC (MMX-LOC) enclosures.



2.0 Installation Instructions

The RAXN-LCD chassis is mounted with four HEX nuts. Figure below shows the RAXN-LCD mounted into a BB-1001(MMX-BBX-1001) backbox. Dimensions for height and mounting hole locations change for the various backboxes as shown in the table below.

BACKBOX MODEL	HEIGHT OF BACKBOX H (IN.)	HORIZONTAL MOUNTING HOLE DIM. A (IN.)	VERTICAL MOUNTING HOLE DIM. B (IN.)
BB-1001(MMX-BB-1001)	9.0"	9.95"	7.5"
BB-1002(MMX-BB-1002)	18.0"	9.95"	16.5"
BB-1003(MMX-BB-1003)	26.5"	9.95"	24.9"
BB-1008(MMX-BB-1008)	33.0"	9.95"	35.2"
BB-1012(MMX-BB-1012)	45.0"	9.95"	52.0"

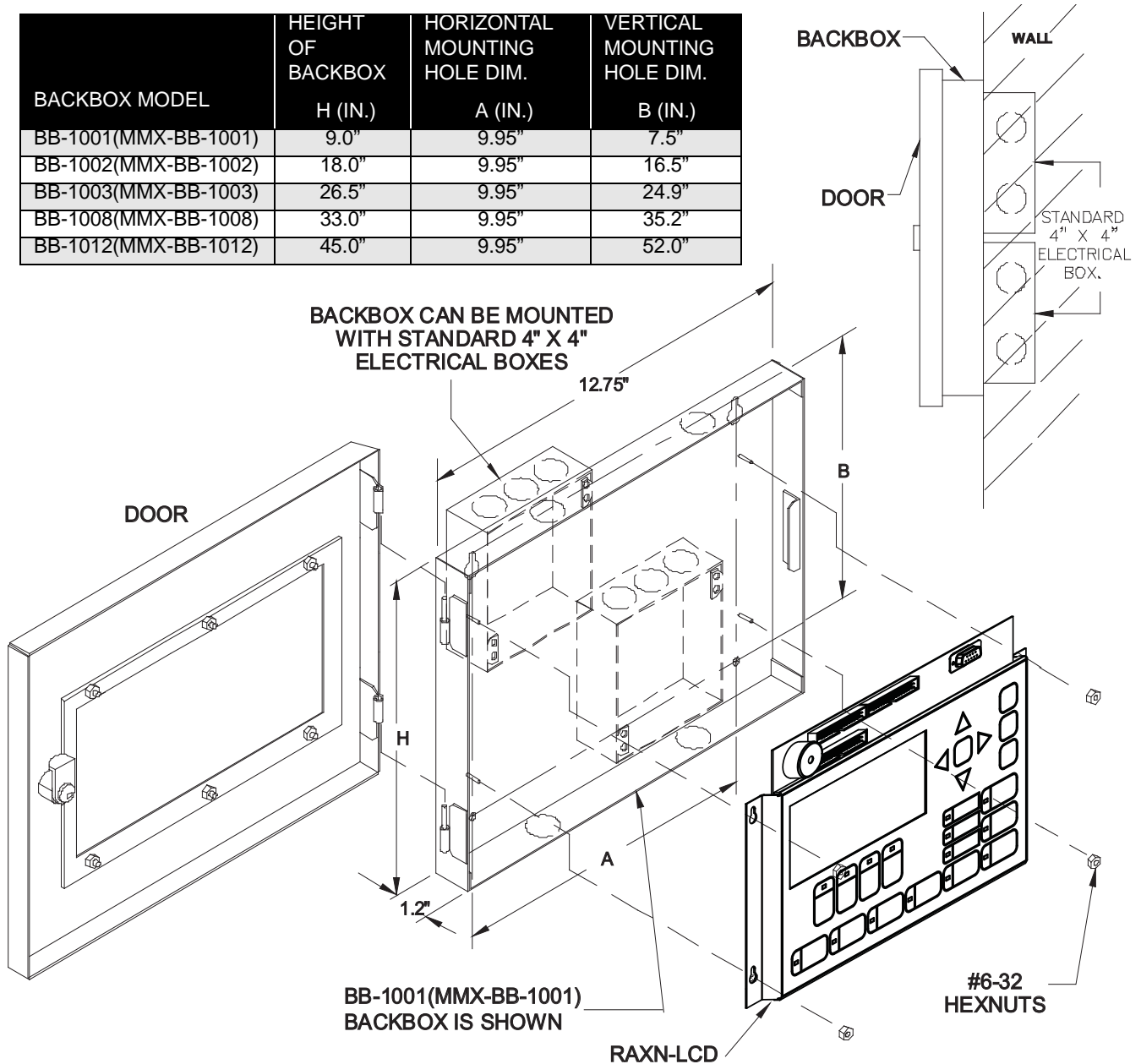

3.0 Jumper Settings

There are 3 jumpers located on the top left-hand side of the board position left to right as JW2, JW1 and JW3.

Jumper	Function
JW1	Left OPEN, used for hard reset
JW2	Jumpered (jumper installed) for watchdog timer
JW3	Left OPEN, if buzzer (located on the right-side of jumper JW3) is to be silenced.



Note: There are jumpers located in connectors P6 and P7. Remove these jumpers when using adder modules beyond the first 13 frames. Refer to the Fire Alarm Panel manual for further details.

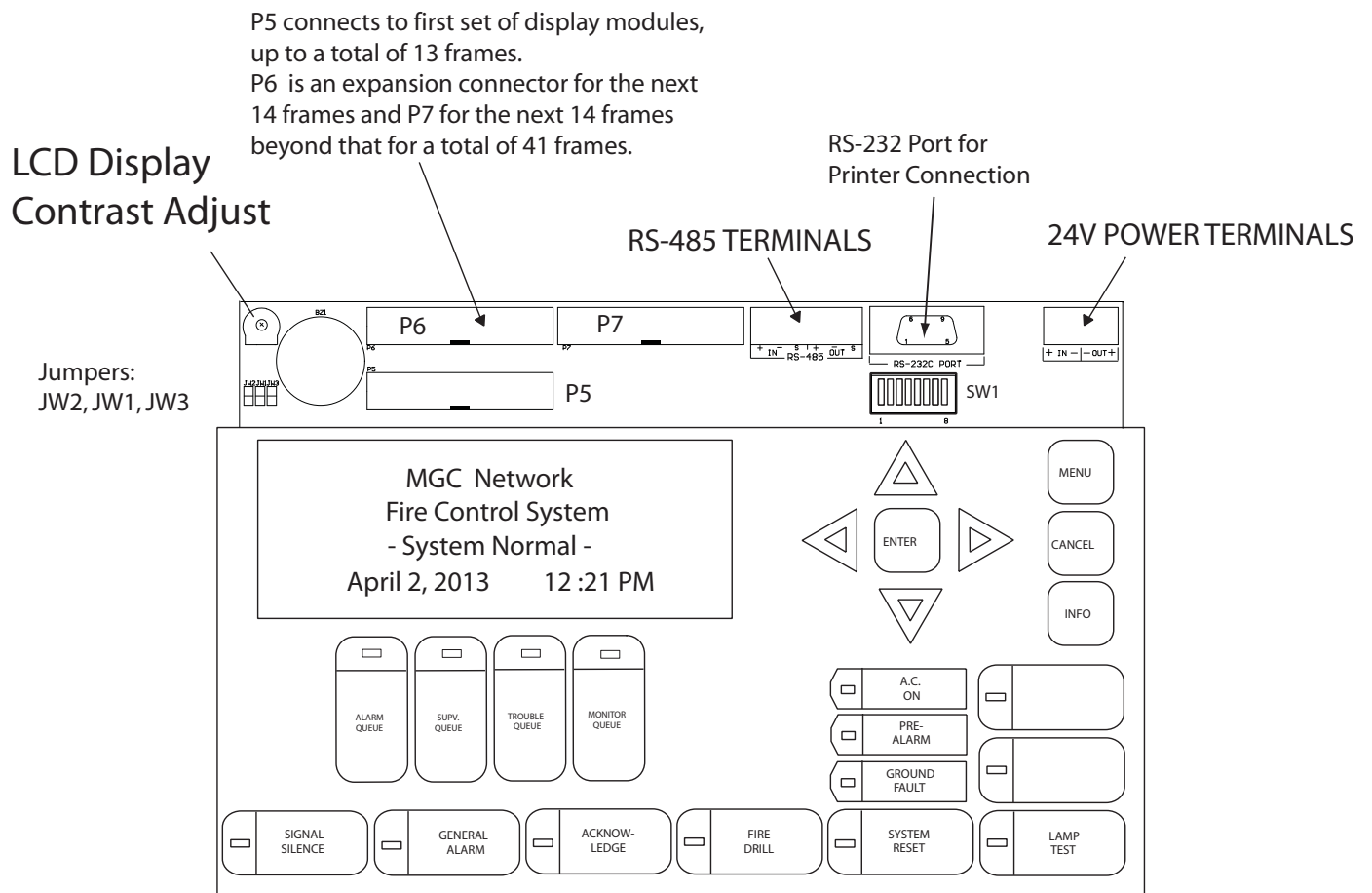

4.0 DIP Switch Settings

Each RAXN-LCD Shared Display Annunciator needs to be assigned a unique address via the DIP switches of SW1.

The RAXN-LCD SW1 DIP switches are set by selecting the active ON. The addresses available for the RAXN-LCD are 33 to 39, inclusive. Set the address as follows in the table below:

RAXN-LCD Remote Annunciator Address Setting (DIP SWITCH SW1)

RAXN-LCD Address	SW1-1	SW1-2	SW1-3	SW1-4	SW1-5	SW1-6	SW1-7	SW1-8
33	ON	OFF	OFF	OFF	OFF	ON		
34	OFF	ON	OFF	OFF	OFF	ON		
35	ON	ON	OFF	OFF	OFF	ON		
36	OFF	OFF	ON	OFF	OFF	ON		
Refer to Network Fire Alarm Manual as to whether addresses 37 to 39 are available							Leave in "OFF" position as Factory Set.	
37	ON	OFF	ON	OFF	OFF	ON		
38	OFF	ON	ON	OFF	OFF	ON		
39	ON	ON	ON	OFF	OFF	ON		

DIP switch SW1 is used to set the address of the RAXN-LCD

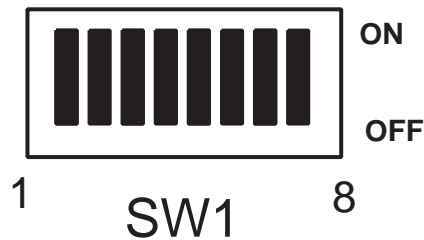

DIP switches are for assigning an address to the RAXN-LCD. Binary addresses 33 to 39 are available with the least significant bit being switch SW1-1 on the left and the most significant bit being SW1-6. The ON setting is active binary. DIP switches SW1-7 and SW1-8 are not used.

For example, address 33 is set by pushing DIP switch SW1-6 and SW1-1 to the ON position and all the other DIP switches to the OFF position.

Refer to Network Fire Alarm Manual as to whether addresses 37 to 39 are available.

5.0 Wiring Instructions

RS-485 Wiring

The RS-485 wiring to the RAXN-LCD Display Module is recommended to be twisted shielded pair as shown in the diagram to the right. The RS-485 wire gauge may be:

- 22 AWG up to 2000 ft.
- 20 AWG up to 4000 ft.

The RS-485 wiring from the fire alarm control panel to the annunciator(s) must be point-to-point from the fire alarm panel to the first annunciator, then to the next annunciator, and so on. No star wiring or T-tapping is allowed.

Each RAXN-LCD Shared Display has a 120 ohm end-of-line resistor on its RS-485 output terminals. This resistor is removed on all except the last wired annunciator.

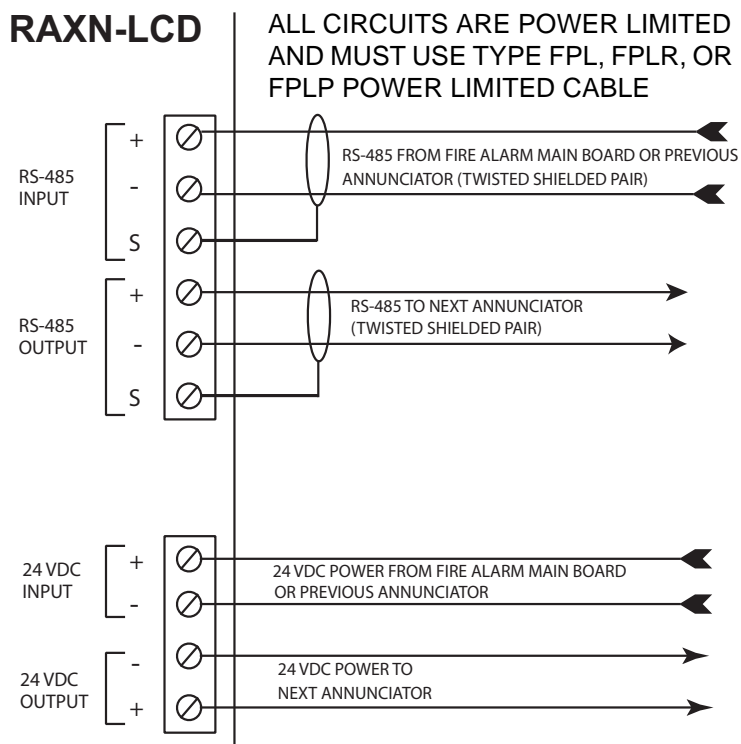

24V DC Wiring

The 24 VDC field wiring needs to be of an appropriate gauge for the number of annunciators and the total wiring run length. Refer to the Current Drain for Battery Calculations on page 8 to calculate the maximum current for all annunciators summed together.



Accidentally connecting any of the 24 VDC wires to the RS-485 wiring will result in damage to the annunciator and/or to the fire alarm control panel to which it is connected.

Total Maximum Current for all Annunciators	Maximum Wiring Run to Last Annunciator								Max. Loop Resistance
	18AWG		16AWG		14AWG		12AWG		
Amperes	ft	m	ft	m	ft	m	ft	m	Ohms
0.12	1180	360	1850	567	3000	915	4250	1296	15
0.30	470	143	750	229	1200	366	1900	579	6
0.60	235	71	375	114	600	183	850	259	3
0.90	156	47	250	76	400	122	570	174	2
1.20	118	36	185	56	300	91	425	129	1.5
1.50	94	29	150	46	240	73	343	105	1.2
1.70	78	24	125	38	200	61	285	87	1.0

6.0 Cable Connections

The RAXN-LCD may be utilized by itself in a remote location or within a larger enclosure together with other display modules. It may also be used as part of a mass notification system.

Below is an example of a RAXN-LCD and a RAX-1048TZ/DS 48 LED Annunciator Display module in a BB-1002 (MMX-BB-1002) enclosure.

Connections on the RAXN-LCD Annunciator

P5: Connects to the RAX-1048TZ/DS 48 LED Annunciator module. This connector may connect up to 13 frames of display modules.

P6: Connects to next 14 frames (i.e. frame 15 to 27) of display modules.

P7: Connects to next 14 frames (i.e. frame 28 to 41) of display modules.

Terminals: Terminal wiring is required for the RS-485 loop and the 24V DC power source. See *Wiring Instructions* on page 5 for details.

SW1: DIP switch SW1 is used to set the address for the RAXN-LCD. See *DIP Switch Settings* on page 6 for details.

Connections on the RAX-1048TZ/DS 48 LED Annunciator Display Module:

P1: Connects to the main annunciator chassis RAXN-LCD P5.

P2: Connects to the next display module if used.

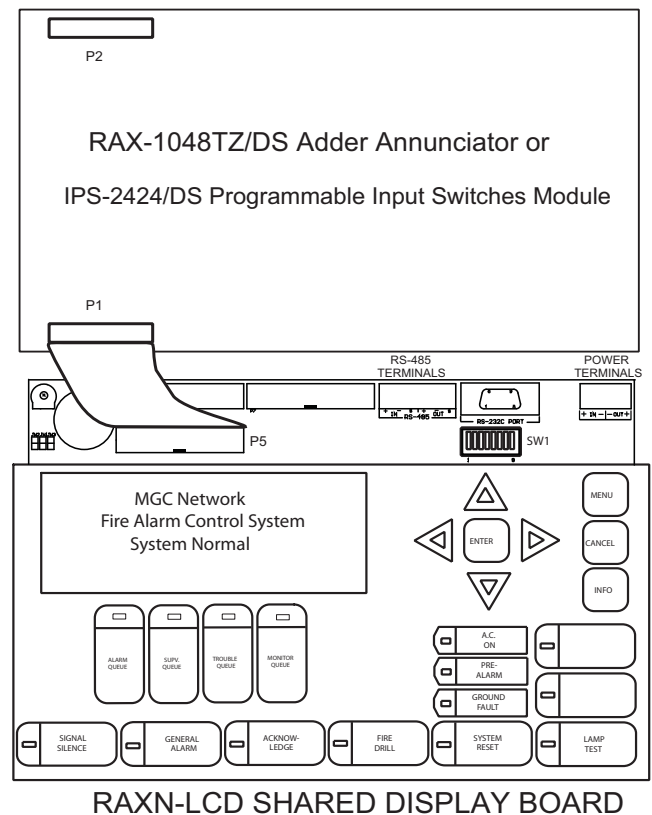

Note: The last annunciator must have a 120 ohm E.O.L. resistor connected to the RS-485 output terminals.

7.0 Specifications

Enclosure Models

BB-1001 (MMX-BB-1001): Backbox for one annunciator chassis with keylock door.

BB-1002 (MMX-BB-1002): Backbox for up to two annunciator chassis with keylock door.

BB-1003 (MMX-BB-1003): Backbox for up to three annunciator chassis with keylock door.

BB-1008 (MMX-BB-1008): Backbox for up to eight annunciator chassis with keylock door.

BB-1012 (MMX-BB-1012): Backbox for up to twelve annunciator chassis with keylock door.



Notes: Enclosure finish: painted semi-gloss off white, except for models with suffix “R” which are painted red.

Material: BB-1001 (MMX-BB-1001), BB-1002 (MMX-BB-1002), BB-1003 (MMX-BB-1003) are 18 GA. (0.048”) thick CRS except the BB-1003 (MMX-BB-1003) Door, which is 16 GA (0.060”). BB-1008 (MMX-BB-1008), BB-1012 (MMX-BB-1012) backboxes are 16 GA. (0.060”) thick CRS, Doors are 14 GA (0.075”) thick.

See *Installation Instructions* on page 6 for enclosure dimensions.

Other larger enclosures available are **BB-5008**, **BB-5014**, **BBX-FXMNS (MMX-BBX-FXMNS)** and **FX-LOC (MMX-LOC)**.

Annunciator Models

RAXN-LCD Remote Network Shared Display LCD Annunciator

- 24V DC nominal.
- Interconnects via one ribbon cable (or wiring) to the Main Network Fire Alarm Panel or to previous RAXN-LCD.
- Provides exact functions as the main display.
- Standby: 139 mA Max., All LED's "On": 164 mA Max.

RAX-1048TZ/DS Adder Annunciator Module (48 Display Points)

- Interconnects via one ribbon cable from RAXN-LCD or to previous RAX-1048TZ/DS or IPS-2424/DS to the next RAX-1048TZ/DS or IPS-2424/DS.
- Annunciation of up to 48 additional points.
- Standby: 22 mA Max., All LEDs On: 262 mA Max.

8.0 Battery Calculations

Current Drain for Battery Calculations

The following are the currents for the RAXN-LCD to which is added the number of RAX-1048TZ/DS and/or IPS-2424/DS or FDX-008KI used:

$$\text{Normal Standby Current} = 139 \text{ mA} + \frac{\text{_____}}{\text{[number of RAX-1048TZ/DS]}} \times 22 \text{ mA} + \frac{\text{_____}}{\text{[number of IPS-2424/DS]}} \times 10 \text{ mA} = \text{_____}$$

$$\text{Maximum Alarm Current} = 164 \text{ mA} + \frac{\text{_____}}{\text{[number of RAX-1048TZ/DS]}} \times 35 \text{ mA} + \frac{\text{_____}}{\text{[number of IPS-2424/DS]}} \times 15 \text{ mA} = \text{_____}$$

The **Normal Standby Current** is used for battery size calculations (see the Network Fire Alarm Manual for battery calculations) and includes the current drain for the Trouble Buzzer, Trouble LED, and one alarm LED. The **Maximum Alarm Current** is used to calculate the wire size required (see Wiring Table on page 3).

9.0 Warranty & Warning Information

Warning Please Read Carefully

Note to End Users: This equipment is subject to terms and conditions of sale as follows:

Note to Installers

This warning contains vital information. As the only individual in contact with system users, it is your responsibility to bring each item in this warning to the attention of the users of this system. Failure to properly inform system end-users of the circumstances in which the system might fail may result in over-reliance upon the system. As a result, it is imperative that you properly inform each customer for whom you install the system of the possible forms of failure.

System Failures

This system has been carefully designed to be as effective as possible. There are circumstances, such as fire or other types of emergencies where it may not provide protection. Alarm systems of any type may be compromised deliberately or may fail to operate as expected for a variety of reasons. Some reasons for system failure include:

•*Inadequate Installation*

A Fire Alarm system must be installed in accordance with all the applicable codes and standards in order to provide adequate protection. An inspection and approval of the initial installation, or, after any changes to the system, must be conducted by the Local Authority Having Jurisdiction. Such inspections ensure installation has been carried out properly.

•*Power Failure*

Control units, smoke detectors and many other connected devices require an adequate power supply for proper operation. If the system or any device connected to the system operates from batteries, it is possible for the batteries to fail. Even if the batteries have not failed, they must be fully charged, in good condition and installed correctly. If a device operates only by AC power, any interruption, however brief, will render that device inoperative while it does not have power. Power interruptions of any length are often accompanied by voltage fluctuations which may damage electronic equipment such as a fire alarm system. After a power interruption has occurred, immediately conduct a complete system test to ensure that the system operates as intended.

•*Failure of Replaceable Batteries*

Systems with wireless transmitters have been designed to provide several years of battery life under normal conditions. The expected battery life is a function of the device environment, usage and type. Ambient conditions such as high humidity, high or low temperatures, or large temperature fluctuations may reduce the expected battery life. While each transmitting device has a low battery monitor which identifies when the batteries need to be replaced, this monitor may fail to operate as expected. Regular testing and maintenance will keep the system in good operating condition.

•*Compromise of Radio Frequency (Wireless) Devices*

Signals may not reach the receiver under all circumstances which could include metal objects placed on or near the radio path or deliberate jamming or other inadvertent radio signal interference.

•*System Users*

A user may not be able to operate a panic or emergency switch possibly due to permanent or temporary physical disability, inability to reach the device in time, or unfamiliarity with the correct operation. It is important that all system users be trained in the correct operation of the alarm system and that they know how to respond when the system indicates an alarm.

•*Automatic Alarm Initiating Devices*

Smoke detectors, heat detectors and other alarm initiating devices that are a part of this system may not properly detect a fire condition or signal the control panel to alert occupants of a fire condition for a number of reasons, such as: the smoke detectors or heat detector may have been improperly installed or positioned; smoke or heat may not be able to reach the alarm initiating device, such as when the fire is in a chimney, walls or roofs, or on the other

side of closed doors; and, smoke and heat detectors may not detect smoke or heat from fires on another level of the residence or building.

•*Software*

Most MGC products contain software. With respect to those products, MGC does not warranty that the operation of the software will be uninterrupted or error-free or that the software will meet any other standard of performance, or that the functions or performance of the software will meet the user's requirements. MGC shall not be liable for any delays, breakdowns, interruptions, loss, destruction, alteration or other problems in the use of a product arising out of, or caused by, the software.

Every fire is different in the amount and rate at which smoke and heat are generated. Smoke detectors cannot sense all types of fires equally well. Smoke detectors may not provide timely warning of fires caused by carelessness or safety hazards such as smoking in bed, violent explosions, escaping gas, improper storage of flammable materials, overloaded electrical circuits, children playing with matches or arson.

Even if the smoke detector or heat detector operates as intended, there may be circumstances when there is insufficient warning to allow all occupants to escape in time to avoid injury or death.

•*Alarm Notification Appliances*

Alarm Notification Appliances such as sirens, bells, horns, or strobes may not warn people or waken someone sleeping if there is an intervening wall or door. If notification appliances are located on a different level of the residence or premise, then it is less likely that the occupants will be alerted or awakened. Audible notification appliances may be interfered with by other noise sources such as stereos, radios, televisions, air conditioners or other appliances, or passing traffic. Audible notification appliances, however loud, may not be heard by a hearing-impaired person.

•*Telephone Lines*

If telephone lines are used to transmit alarms, they may be out of service or busy for certain periods of time. Also the telephone lines may be compromised by such things as criminal tampering, local construction, storms or earthquakes.

•*Insufficient Time*

There may be circumstances when the system will operate as intended, yet the occupants will not be protected from the emergency due to their inability to respond to the warnings in a timely manner. If the system is monitored, the response may not occur in time enough to protect the occupants or their belongings.

•*Component Failure*

Although every effort has been made to make this system as reliable as possible, the system may fail to function as intended due to the failure of a component.

•*Inadequate Testing*

Most problems that would prevent an alarm system from operating as intended can be discovered by regular testing and maintenance. The complete system should be tested as required by national standards and the Local Authority Having Jurisdiction and immediately after a fire, storm, earthquake, accident, or any kind of construction activity inside or outside the premises. The testing should include all sensing devices, keypads, consoles, alarm indicating devices and any other operational devices that are part of the system.

•*Security and Insurance*

Regardless of its capabilities, an alarm system is not a substitute for property or life insurance. An alarm system also is not a substitute for property owners, renters, or other occupants to act prudently to prevent or minimize the harmful effects of an emergency situation.

IMPORTANT NOTE: End-users of the system must take care to ensure that the system, batteries, telephone lines, etc. are tested and examined on a regular basis to ensure the minimization of system failure.

Limited Warranty

Mircom Technologies Ltd., MGC Systems Corp. and MGC System International Ltd. together with their subsidiaries and affiliates (collectively, MGC) warrants the original purchaser that for a period of three years from the date of shipment, proprietary manufactured product shall be free of defects in materials and workmanship, under normal use. During the warranty period, MGC shall, at its option, repair or replace any defective product upon return of the product to its factory, at no charge for labor and materials. Non-proprietary, third party or OEM product shall be warranted in accordance with the warranty period of the manufacturer. Any replacement and/or repaired parts are warranted for the remainder of the original warranty or ninety (90) days, whichever is longer. The original owner must promptly notify MGC in writing that there is defect in material or workmanship, such written notice to be received in all events prior to expiration of the warranty period.

International Warranty

The warranty for international customers is the same as for any customer within Canada and the United States, MGC shall not be responsible for any customs fees, taxes, or VAT that may be due.

Conditions to Void Warranty

This warranty applies only to defects in parts and workmanship relating to normal use. It does not cover:

- damage incurred in shipping or handling;
- damage caused by disaster such as fire, flood, wind, earthquake or lightning;
- damage due to causes beyond the control of MGC such as excessive voltage, mechanical shock or
- water damage;
- damage caused by unauthorized attachment, alterations, modifications or foreign objects;
- damage caused by peripherals (unless such peripherals were supplied by MGC);
- defects caused by failure to provide a suitable installation environment for the products;
- damage caused by use of the products for purposes other than those for which it was designed;
- damage from improper maintenance;
- damage arising out of any other abuse, mishandling or improper application of the products.

Warranty Procedure

To obtain service under this warranty, please return the item(s) in question to the point of purchase. All authorized distributors and dealers have a warranty program. Anyone returning goods to MGC must first obtain an authorization number. MGC will not accept any shipment whatsoever for which prior authorization has not been obtained. NOTE: Unless specific pre-authorization in writing is obtained from MGC management, no credits will be issued for custom fabricated products or parts or for complete fire alarm system. MGC will at its sole option, repair or replace parts under warranty. Advance replacements for such items must be purchased.

Note: MGC's liability for failure to repair the product under this warranty after a reasonable number of attempts will be limited to a replacement of the product, as the exclusive remedy for breach of warranty.

Disclaimer of Warranties

This warranty contains the entire warranty and shall be in lieu of any and all other warranties, whether expressed or implied (including all implied warranties of merchantability or fitness for a particular purpose) and of all other obligations or liabilities. MGC neither assumes nor authorizes any other person purporting to act on its behalf to modify or to change this warranty, or to assume for it any other warranty or liability concerning this product.

This disclaimer of warranties and limited warranty are governed by the laws of the province of Ontario, Canada.

Out of Warranty Repairs

MGC will at its option repair or replace out-of-warranty products which are returned to its factory according to the following conditions. Anyone returning goods to MGC must first obtain an authorization number. MGC will not accept any shipment whatsoever for which prior authorization has not been obtained.

Products which MGC determines to be repairable will be repaired and returned. A set fee which MGC has predetermined and which may be revised from time to time, will be charged for each unit repaired.

Products which MGC determines not to be repairable will be replaced by the nearest equivalent product available at that time. The current market price of the replacement product will be charged for each replacement unit.

The foregoing information is accurate as of the date of publishing and is subject to change or revision without prior notice at the sole discretion of the Company

WARNING: MGC recommends that the entire system be completely tested on a regular basis. However, despite frequent testing, and due to, but not limited to, criminal tampering or electrical disruption, it is possible for this product to fail to perform as expected.

NOTE: Under no circumstances shall MGC be liable for any special, incidental, or consequential damages based upon breach of warranty, breach of contract, negligence, strict liability, or any other legal theory. Such damages include, but are not limited to, loss of profits, loss of the product or any associated equipment, cost of capital, cost of substitute or replacement equipment, facilities or services, down time, purchaser's time, the claims of third parties, including customers, and injury to property.

MGC MAKES NO WARRANTY OF MERCHANTABILITY OR FITNESS FOR A PARTICULAR PURPOSE WITH RESPECT TO ITS GOODS DELIVERED, NOR IS THERE ANY OTHER WARRANTY, EXPRESSED OR IMPLIED, EXCEPT FOR THE WARRANTY CONTAINED HEREIN.

Notes



CANADA - Main Office
25 Interchange Way
Vaughan, ON L4K 5W3
Tel: (888) 660-4655
(905) 660-4655
Fax: (905) 660-4113

U.S.A
4575 Witmer Industrial Estates
Niagara Falls, NY 14305
Tel: (888) 660-4655
(905) 660-4655
Fax: (905) 660-4113

TECHNICAL SUPPORT
North America
Tel: (888) Mircom5
(888) 647-2665
International
Tel: (905) 647-2665

© MGC 2013
Printed in Canada
Subject to change without prior notice

www.mircomgroup.com