

TEXAS AVE DOG PARK

CONSTRUCTION KICKOFF COMMUNITY MEETING



June 14, 2023



RULES OF THE ROAD

Welcome! Thank you for your participation.

- Please Hold all questions until the end of the presentation.
- Sign-In Before you leave (QR Code top right).
- Please turn on your Closed Captioning (CC) to assist in hearing questions.
- We'll do our best to answer all questions, but if a question is not answered, DPR is tracking all questions and will create a Q/A document to be shared after the meeting.
- Meeting is being recorded.



Email List Sign-in
DPR.DC.GOV/ATTENDEE

AGENDA

1. Team Introductions
2. Project Overview
3. Project Timeline
4. Contact Information
5. Questions and Answers



DC GOVERNMENT PRESENTERS

- Christopher Dyer
DPR Community Engagement Manager
- Dulce Naime
DPR Project Manager
- Jamie Johnson
DGS Project Manager



DESIGN / BUILD TEAM

- Wilson Matos
WKM Solutions - Project Manager
- Julian Arias
WKM Solutions - Project Coordinator

- Griffen Pine
Century Engineering - Civil Engineer
- Piero Mellits
Century Engineering - Civil Engineer



PROJECT OVERVIEW

PROJECT BUDGET: \$820,249.66

OBJECTIVE: To build the first off-leash dog park in Ward 7.

PROGRAM:

- Two distinct fenced dog play areas for small and large dog breeds with shade, water fountains, benches, and bag dispensers
- Grilling and picnic areas,
- Trash and recycling receptacles, and
- Green spaces and bioretention areas.

PROJECT OVERVIEW



LEGEND

- Existing Boundary
- Minor Contour
- Major Contour
- Existing Tree Line
- Existing Building
- Proposed Dog Park Area
- Proposed Microbioretention
- Proposed SD Manhole
- Proposed Fence
- Proposed Gate
- Proposed Shade Tree



PROJECT OVERVIEW



Surfacing

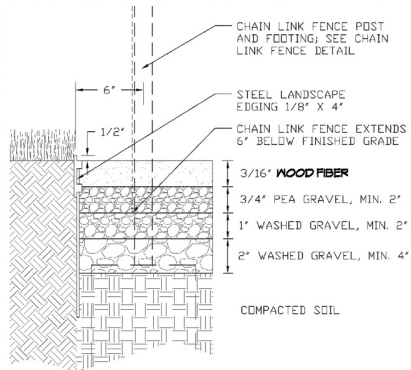

NOTES
ALL SURFACES ARE TO BE COMPACTED TO MINIMUM 90% STANDARD DENSITY
STEEL EDGING BY BORDER CONCEPTS, INC., OR EQUAL



Shade Structure



Fencing

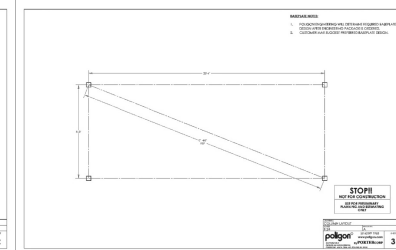
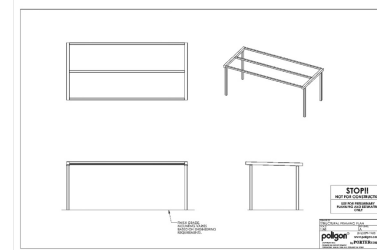
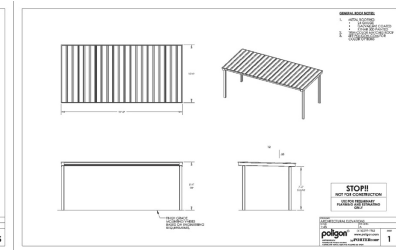
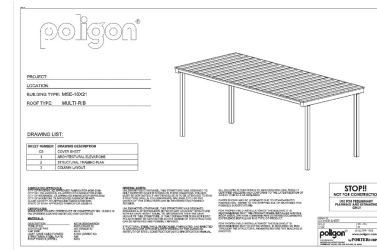
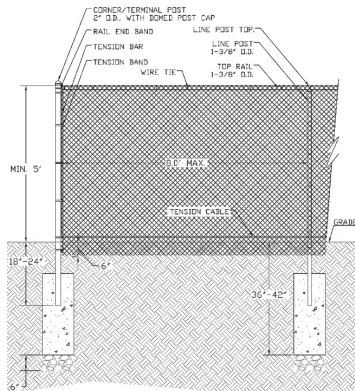

PROJECT OVERVIEW



Water fountain



Storage



Bag dispensers

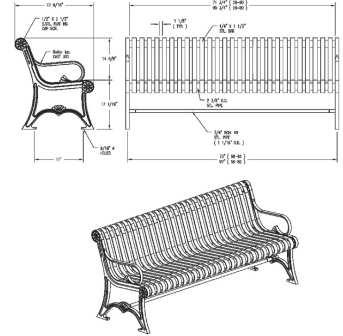

Benches



Standard DPR signs



Picnic tables



DPR Recycling / Trash

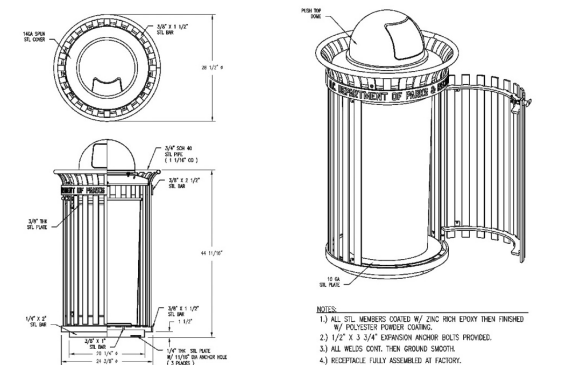

PROJECT TIMELINE

- 1st Project Solicitation February 20 21
- Additional funding added to the project August 20 21
- 2nd Project Solicitation November 20 21
- Hired Design/Build firm March 20 22
- Design & Agency planning meetings March - August 20 22
- Permitting Winter-Summer 20 23
- Construction Start Summer 20 23
- Construction Completion Winter 20 24*

** Weather and supply chain pending*

CONTACT INFORMATION

Department of General Services (DGS)

Wayne Gore, Community Engagement and Outreach Coordinator

wayne.gore@dc.gov

Department of Parks & Recreation (DPR)

Dulce Naime / Project Manager

dulce.naime@dc.gov

Christopher Dyer / Community Engagement Manager

christopher.dyer@dc.gov



Email List Sign-in
[DPR.DC.GOV/ATTENDEE](https://dpr.dc.gov/attende)

Project Website:

<https://dgs.dc.gov/page/texas-avenue-dog-park1-0>

QUESTIONS

