



## MacFarland Middle School Call to Artists

### Opportunity

The Department of General Services (“Department” or “DGS”) is issuing this Request for Qualifications (RFQ) to engage individual artists and artistic teams (Artist) to respond to this Call to Artists with professional qualifications in addition to a proposal of site-specific artistic capital improvements for the renovation and additions to MacFarland Middle School, located 4400 Iowa Avenue, N.W., Washington, D.C. 20011 in Ward 4. The Artists shall develop a new original permanent work of art made specifically for the site.

Location	Restrictions	Location Description from package	Type	Final Commission
1	DC ONLY	Main Entry Lobby	2 or 3 Dimensional	25000
2		Media center Murals	2 Dimensional	25000
3		2 Rear Entry Vestibules	3 Dimensional - Suspended	50000
4		Outdoor Classroom	Decorative Exterior Screening (Metal, Etched glass...)	30000
5	DC ONLY	Cafeteria Feature Wall	2 Dimensional - Light art	10000
6	DC ONLY	Corridor Artwork	2 Dimensional	30000
			Total Commissions	<b>170000</b>

There are two (2) selection processes:

Request for Qualifications (RFQ), whereby an Artist and/or Team submits images of prior work demonstrating a minimum of five years of site-specific public art experience.

**APPLICATION DEADLINE: 12/31/2017**

**SEMI-FINALISTS ANNOUNCED: 1/19/2018**

The finalist for each location will be determined through an Art Selection Committee selection process. This will be a commission for a new original permanent work of art made specifically for the site. Finalists site visits and community input session(s) will be conducted in concert with the Art Selection Committee prior to the submittal of a site-specific design proposal.

**SITE SPECIFIC DESIGN PROPOSAL DEADLINE: 2/16/2018**

Site Specific Design Proposals shall include or consider the following:

- Fabricated from durable, low-maintenance material that can withstand the elements and requires minimal maintenance. This work will be permanently installed in a school and must be able to withstand a school environment with very active children.
- The work commissioned is for permanent installation and therefore should last for at least 50 years.
- Incorporate context of the local community, with sensitivity to the history, traditions and iconography that uplift the pride of the community.
- Adhere to requisite ADA and safety regulations.
- Engaging and enjoyable to individuals of all ages and backgrounds.
- DGS will prepare the site for installation, which could include blocking walls for reinforcement, concrete pads for exterior works and lighting. HOWEVER, it is important for the artist to remember that installation is included in the artist's budget – including lifts, cabling, bolting, etc. The artist will work with DGS to confirm installation arrangements.
- We do have a list of local museum installers, rental companies and printers that can be of assistance if needed.
- Since our installations are located in very active environments (schools, shelters, recreation centers, etc.), it is crucial that your proposal consists of materials and/or coatings that are durable. For instance, for paintings and other flat surfaces, we require two coats of UV/graffiti protection. For paintings, we typically have them pasted onto the surface with a simple wood frame built around it – so that if the work needs to be removed in the future, it can be saved and carefully removed from the original location. If the artwork is installed at human height level, your work should be able to withstand touching and be extremely durable and easily cleaned. These details can be fleshed out in final design but should be accounted for in your budget.
- **Three (3) References from recent projects**

## Resources

**Design Documents for MacFarland Elementary School: See Attachment A.**

## **Eligibility**

The competition is open to professional artists with a minimum of five years of site-specific and/or public art experience. Some categories are restricted to artists from Washington, D.C. or represented by a D.C. gallery. Artists should have demonstrated experience working with community representatives, youth, businesses and government entities. It is also important that if the artist(s) selected for the project actively engage and collaborate with local residents.

## **Selection Criteria & Process**

The selection committee, representing diverse interests and expertise, will review images submitted by artists and recommend (3) three to (5) five Finalists for each project. Each Finalist will be awarded a \$500 honorarium to create a site-specific design proposal that would include a scale model or rendering, an itemized budget, a project timeline, and a project narrative. An additional \$500 is allocated for artists who've been selected as finalists and reside outside of Maryland, DC or Virginia for travel to present models. Note the schedule. Finalists will be notified by email. We will do everything humanly possible to get your design and travel checks prior to the presentation – but in all likelihood it will not arrive in time for you to book your flight. We will also schedule the panel meeting so that you can arrive the morning of and fly out the evening of – to help save on hotel costs. The easiest airport to use is Reagan National "DCA".

Finalists should attend the site visit (but we will share pictures to everyone via email) and definitely attend the panel presentation to the selection committee. If your presentation is via skype (which we do NOT encourage – the travel honoraria must be waived.)

The selection committee will review the designs, references will be checked and then (1) one finalist/team for the project will be recommended.

The following Public Art Evaluation Criteria will be used for the Finalist:

**Artistic Content**

80 %

The applicant's work sample and support materials (brochures, articles, letters of support, etc.) demonstrate high standards of artistic excellence within the chosen discipline(s);  
Artist(s) and/or applicant's written concept exhibits high quality, innovation and creativity  
Applicant has experience with site specific public art projects and uses personnel with demonstrated arts expertise (such as arts administrator, professional artists) to plan and implement artistic content;  
The described project, goals and schedule of planned activities are feasible;  
The applicant demonstrates a commitment to hiring DC-based artists, where applicable, to deliver artistic content (such as arts administrators, professional artists); and  
Artist(s) and/or applicant demonstrate the ability to translate artistic discipline to project participants.  
The Artist's portfolio of work is feasible for this particular project.

**Community Engagement and Impact**

10 %

Project provides shared learning opportunities in the District that facilitate a greater participation in the arts, relative to the artistic discipline  
Applicant demonstrates sensitivity to the cultural, ethnic and economic background of the participants and the residents of the District of Columbia  
Project addresses significant diversity of expression;  
Project addresses needs of the community;  
Project location(s) and presentation(s) are accessible to persons with disabilities; and  
Applicant has substantive experience working with community representatives, landscape architects, business and government entities  
***If the applicant is a resident of the District of Columbia or has a studio located in the District of Columbia or is represented by a gallery located in the District of Columbia, the applicant automatically receives the full 10% credit for the this category.***

**Capacity and Sustainability**

10 %

The applicant is sufficiently stable, in terms of arts expertise, organizational capacity, and financial status to implement the proposed project;  
The applicant demonstrates the internal capacity to administer the project and has appropriate financial monitoring systems in place to track expenditures  
The applicant's budget information is detailed, accurate, feasible, and directly related to the project. All items are eligible expenses;  
The applicant has experience in producing similar public art projects;  
The work of art is designed to last for at least 50 years;  
and  
The design proposal and the selection committee's recommendations will be forwarded to the DGS for review and final approval. The artist whose design is approved will then enter into an agreement with DGS for final design, fabrication and installation of the artwork.

The final selection is conditioned upon a positive reference check.

## Project Goals, Themes, & Budget

This Call for Artists seeks works of art for 9 spaces throughout the school and school grounds. Please be very specific (referring to Artist number) as which piece(s) of art you are responding to.

**The total budget for each project is as follows:**

Location	Restrictions	Location Description from package	Type	Final Commission
1	DC ONLY	Main Entry Lobby	2 or 3 Dimensional	25000
2		Media center Murals	2 Dimensional	25000
3		2 Rear Entry Vestibules	3 Dimensional - Suspended	50000
4		Outdoor Classroom	Decorative Exterior Screening (Metal, Etched glass...)	30000
5	DC ONLY	Cafeteria Feature Wall	2 Dimensional - Light art	10000
6	DC ONLY	Corridor Artwork	2 Dimensional	30000
			Total Commissions	<b>170000</b>

The indicated budget must include ALL artists' fees and costs associated with design, fabrication, travel, transportation of work to the site, insurance, permits, installation and documentation of the artwork.

## Calendar and Timeline

Project Timeline	
Call/RFQ Released:	<b>By 11/17/2017</b>
Question submission deadline	<b>By 12/1/2017</b>
Responses to questions issued	<b>By 12/8/2017</b>
Submission Deadline for RFQ:	<b>By 12/31/2017</b>
First Round Panel Review & Announcement	<b>By 1/12/2018</b>
Semi-finalists Notified and Announced:	<b>By 1/19/2018</b>
Site Visit Tour with Semi-Finalists: Note – artists from outside of the DC area are not expected to attend due to the modest travel stipend meant primarily for the panel presentation of your proposal – but we will email you photographs and a list of questions and answers during the site visit.	<b>1/24/2018 11 am</b>
Site-Specific Proposals Due: Bring your models with you to avoid damage during shipping and to save shipping costs. You will take your models back with you. Email your CAD/illustrations two business days before the panel so we know what to expect.	<b>By 2/16/2018</b>
Proposal Presentation:	<b>2/21/2018 9am</b>
Reference Checks:	<b>By 3/2/2018</b>
Finalist Announced:	<b>By 3/9/2018</b>
Contract Executed:	<b>By 3/31/2018</b>
Final Design & Fabrication (3 months)	<b>Between 4/2018 and 7/2018</b>
Installation Complete deadline:	<b>By 7/30/2018</b>

# RFQ SUBMISSION REQUIREMENTS

## 1. Round One – Submit Resume, 10 Images and Letter of Interest VIA EMAIL

(Design proposals are NOT accepted at this stage.)

**PLEASE EMAIL A COPY OF ALL THE FOLLOWING TO SANDY.BELLAMY@DC.GOV**

We digitize all qualification packages for panel review anyway, so it is much better to just email them.

You can use Google file sharing or Dropbox for large files.

1. Complete **APPLICATION FORM. Attachment A**
2. One Page **Letter of Intent (which can be your cover email)** stating your interest in and qualifications for the project.
3. Describe in detail the approach to engage the community. Within the letter, outline your past experiences working with communities.
4. Include up to **10 DIGITAL** images of previous artwork. Images should be numbered to correspond with the **Image identification List in Attachment A**. Example: 01\_Jones; 02\_Jones. Please take time to present your artwork with high quality photographs and a cohesive selection of your images that best reflects your work. Ask a photographer to take images of your work. Your images are what represent you in this round.
5. Include your current artistic **RESUME** highlighting experience with site-specific work and public art commissions.
6. Please make a copy of the application to keep for your records.

## 2. Round Two – Submit Model and Design Proposals

**TO SUBMIT MODELS FOR ROUND 2:**

**-EMAIL CAD/GRAPHICS AND PHOTOGRAPHS OF YOUR ACTUAL MODEL THE MONDAY PRIOR TO THE PRESENTATION SO WE KNOW WHAT TO EXPECT.** (We are commissioning quite a number of works and would like to pre-organize submissions prior to your arrival. We digitize all materials, so it is much better to just email them. You can use Google file sharing or Dropbox for large files.)

**-BRING YOUR MODELS (AND FLASH DRIVES ALONG WITH 10 COPIES PRINTED HARD COPIES OF YOUR PROPOSAL) WITH YOU TO PREVENT THEM FROM BEING DAMAGED DURING SHIPPING AND TO SAVE YOU SHIPPING COSTS. WHEN IT IS YOUR TURN TO SUBMIT, YOU WILL BE ASKED FOR YOUR FLASH DRIVE AND HARD COPIES. BE PREPARED TO TAKE YOUR MODELS BACK WITH YOU AFTER YOUR PRESENTATION SO KEEP YOUR BOX AND PACKING MATERIALS ORGANIZED. WE WILL HAVE PACKING TAPE THERE FOR YOU.**

**-THE PRESENTATION WILL BE HELD AT:**

D.C. Department of General Services  
4<sup>th</sup> Floor Conference Room  
1250 U Street, N.W., Suite 300  
Washington, D.C. 20020  
Attn: Sandy Bellamy

**-NOTE: PLEASE CAREFULLY PACK YOUR MODEL FOR EXTRA PROTECTION. SHIPPERS/AIRLINES ARE KNOWN TO THROW PACKAGES BREAKING MODELS AND WE DON'T WANT TO HAVE YOU GO THROUGH THE FRUSTRATION OF TRYING TO REPAIR YOUR MODEL BEFORE YOUR PRESENTATION.**

- 3. QUESTIONS – E-mail to [sandy.bellamy@dc.gov](mailto:sandy.bellamy@dc.gov). Do NOT leave questions on voice mail. Questions and answers will be shared with all participants.**

## **About DGS and the Percent for Art program**

The Department of General Services (DGS) began its percent for art program in 2013 as a way to support our local creative economy and complement our award-winning architecture with diverse and inspiring permanent works of art. Since inception, DGS has commissioned nearly 150 works of art for nearly 10 properties – about 75 new works of art per year for the city. Our portfolio includes schools, shelters, parks and recreation and office buildings. Note: our sister agencies – the DC Commission on Arts and Humanities has a very robust public art program, as does DC Libraries and DC Department of Transportation. In addition, in D.C., the GSA and Metro who also have very robust public art programs. Thus, we are honored to do our part in a vibrant network of cultural resources in Washington, D.C. to support artists and elevate our built environment.

Our commissions range from large scale exterior sculptures, installations, suspended works of art, mixed media, paintings, illustrations, graphics, photography, furniture and even poetry. The program always reserves at least 50% of its commissions to DC artists or artists represented by DC galleries to ensure that our tax dollars are reinvested back into our local community. Even artists from outside of D.C. typically contribute to our local creative economy by working with local fabricators, printers, equipment rental outfits and installers – some of whom have even taken on emerging artists as assistants for installation and as mentees. All in all, we have a profound and deep gratitude for the artists, architects, construction teams and community who contribute to each commission.

The Department of General Services (DGS) has a mission to elevate the quality of life for the District with superior construction, first-rate maintenance and expert real estate management. By building and maintaining safe and green state-of-the-art facilities which foster economic growth and elevate educational environments, our trusted and skillful employees create modern and vibrant communities across all of the District of Columbia.

The Department of General Services (DGS), a newly established District agency, provides cost-effective, centralized facility management services. In October of 2011, the agency assumed the functions and responsibilities of the Department of Real Estate Services (DRES), Office of Public Education Facilities Modernization (OPEFM), Municipal Facilities: Non-Capital agency, and the capital construction and real property management functions of several other District agencies.

DGS improves the efficiencies of basic services, while removing redundancies, to provide the most cost-effective management and ensure the best value of the District's property acquisition, construction and maintenance resources.

**ATTACHMENT A  
APPLICATION FORM**

MacFarland Middle School Call to Artists

DEADLINE DATE:

Name \_\_\_\_\_

Address \_\_\_\_\_

City \_\_\_\_\_ State \_\_\_\_\_ Zip \_\_\_\_\_

Daytime Phone \_\_\_\_\_ Email \_\_\_\_\_

I have reviewed Attachment #1 and I am applying to be Artist #:

    #1    #2    #3    #4    #5    #6    

IMAGE IDENTIFICATION LIST

---

Title	Materials	Dimensions	Year/Location	Budget/Price
-------	-----------	------------	---------------	--------------

---

Title	Materials	Dimensions	Year/Location	Budget/Price
-------	-----------	------------	---------------	--------------

---

Title	Materials	Dimensions	Year/Location	Budget/Price
-------	-----------	------------	---------------	--------------

---

Title	Materials	Dimensions	Year/Location	Budget/Price
-------	-----------	------------	---------------	--------------

---

Title	Materials	Dimensions	Year/Location	Budget/Price
-------	-----------	------------	---------------	--------------

---

Title	Materials	Dimensions	Year/Location	Budget/Price
-------	-----------	------------	---------------	--------------

---

Title	Materials	Dimensions	Year/Location	Budget/Price
-------	-----------	------------	---------------	--------------

---

Title	Materials	Dimensions	Year/Location	Budget/Price
-------	-----------	------------	---------------	--------------

---

Title	Materials	Dimensions	Year/Location	Budget/Price
-------	-----------	------------	---------------	--------------

---

Title	Materials	Dimensions	Year/Location	Budget/Price
-------	-----------	------------	---------------	--------------



## MACFARLAND MIDDLE SCHOOL

MacFarland Middle School will house 6th through 8th grade students. The school is proposed as a neighborhood school as well as offering bi-lingual or advanced language programs. The site is adjacent to the global studies focused Roosevelt Senior High School, for which MacFarland is the primary feeder school.

Henry B MacFarland Junior High School opened in 1923. Henry MacFarland was an American politician who served as a member and president to the D.C. Board of Commissioners.

The school's architect was Albert Harris, Municipal Architect starting in 1921. Harris developed a prototype that was repeated and reconfigured for several schools to accommodate different conditions and requirements throughout the district. The building is red brick and limestone in the Colonial Revival/Neo Classical style.

The school is located at 4400 Iowa Avenue NW, Washington DC, in the Petworth neighborhood in Lower Ward 4 of the city. In addition to the significant population of Spanish speaking families in the boundary, two of the feeder schools have dual language English and Spanish programs.

The school's mascot is the Mustang and the school colors are red and black.



**ART LOCATION 1:**

MAIN ENTRY LOBBY, DOUBLE HEIGHT SPACE

**CONCEPT:**

PLAYFUL/DYNAMIC SCULPTURE ALONG BEAMS

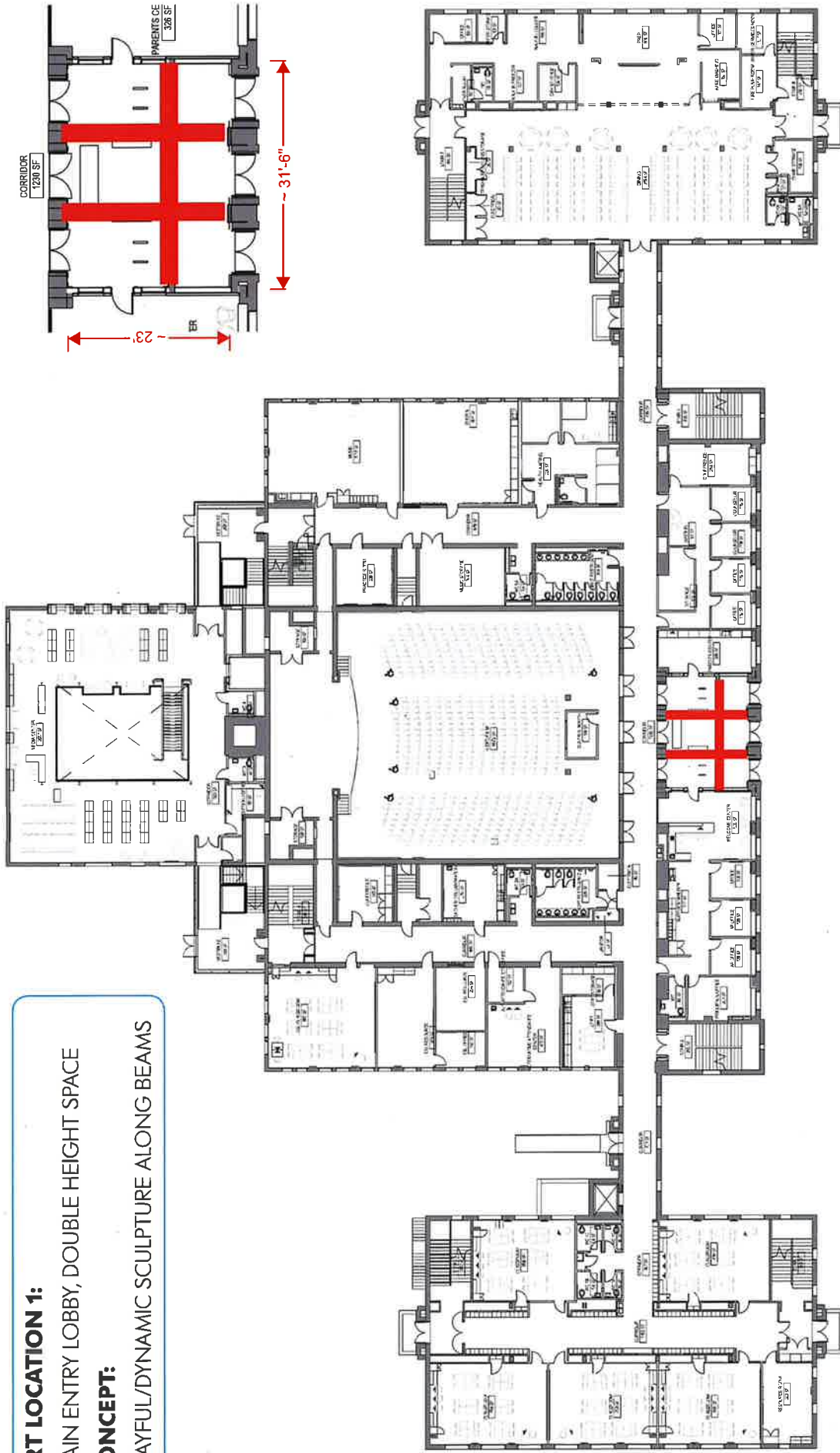

\*NOTE: ALL DIMENSIONS TO BE VERIFIED IN FIELD

**ART LOCATION 1: FIRST FLOOR PLAN**  
**DGS - MACFARLAND MIDDLE SCHOOL**

October 2017

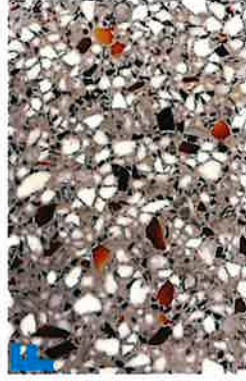
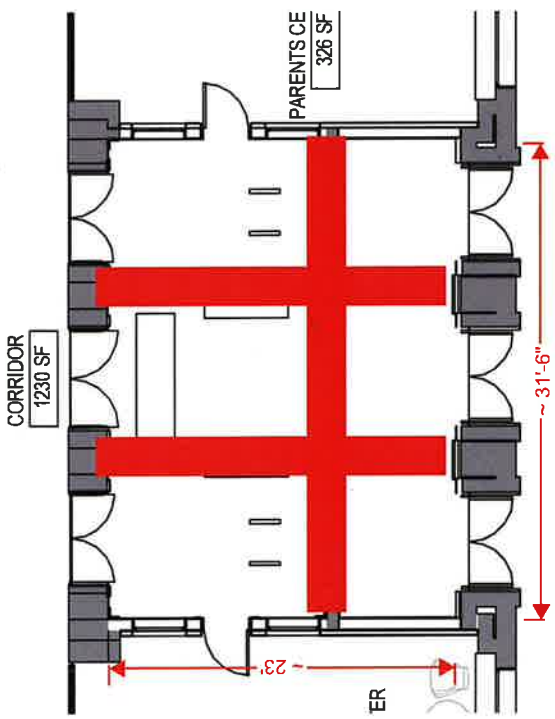
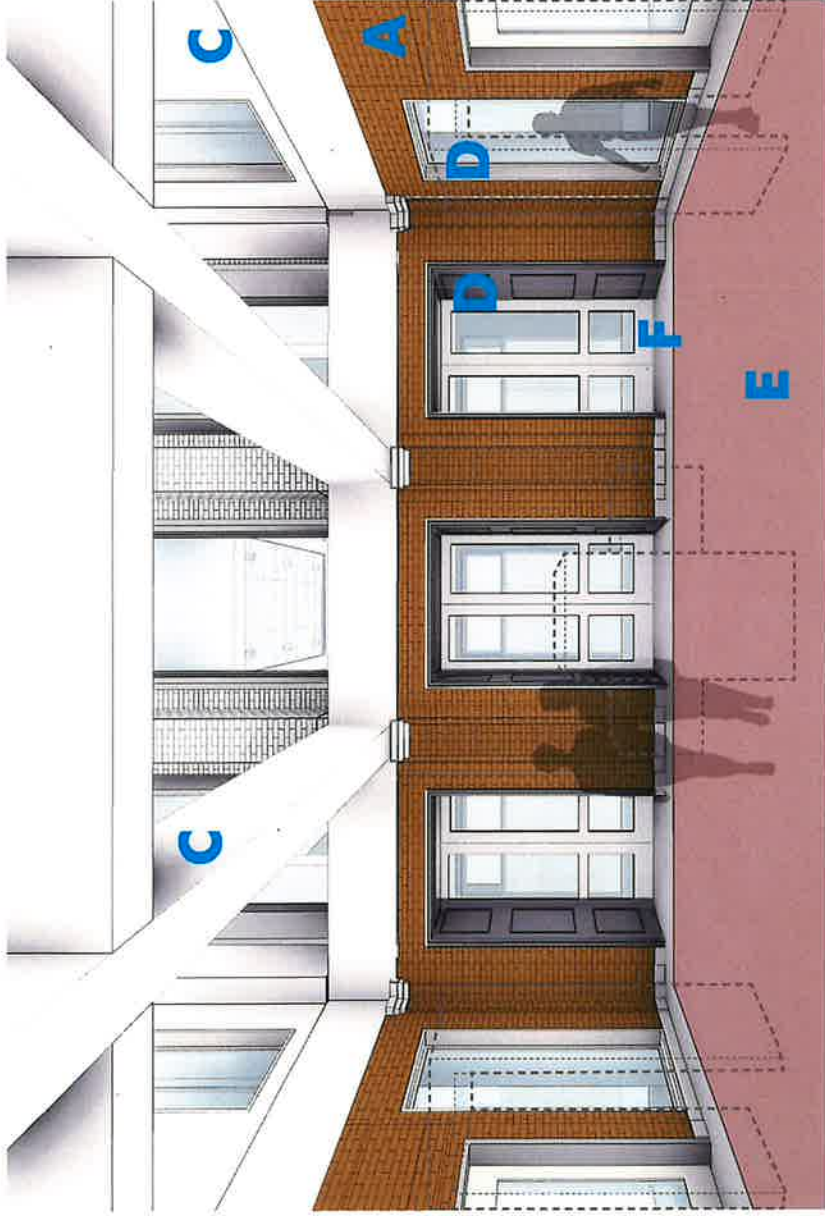

**\*NOTE: ALL DIMENSIONS TO BE VERIFIED IN FIELD**  
**ART LOCATION 1: VIEW TOWARDS AUDITORIUM**  
**DGS - MACFARLAND MIDDLE SCHOOL**

October 2017

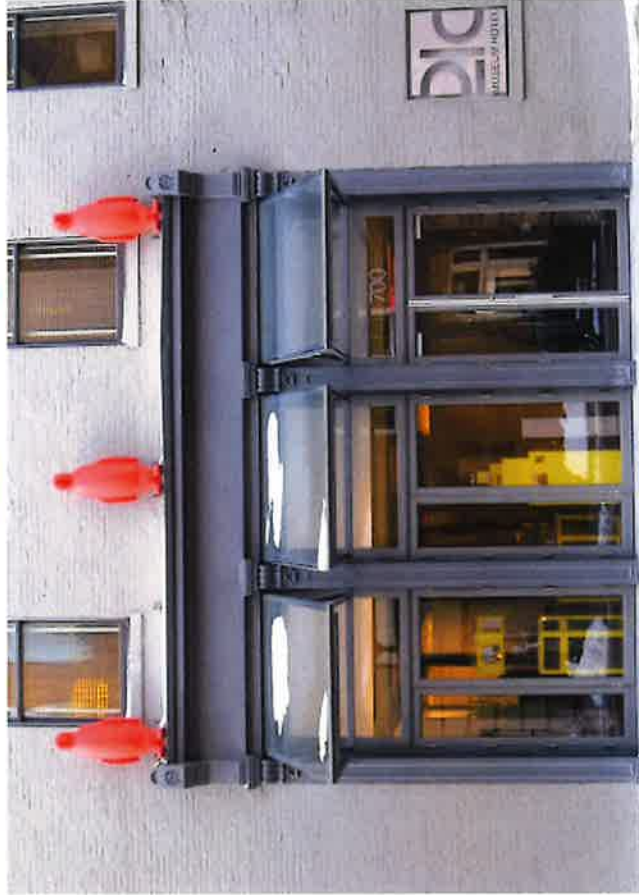
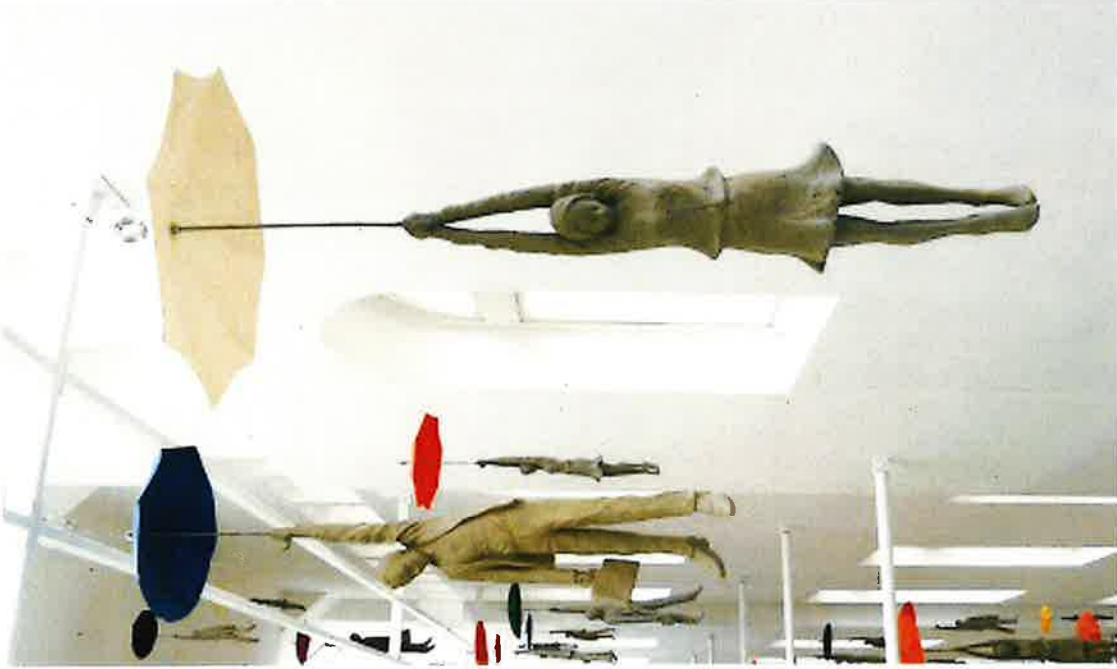

**ART LOCATION 1: MAIN LOBBY - SCULPTURE CONCEPT IMAGES**  
DGS - MACFARLAND MIDDLE SCHOOL

November 2017

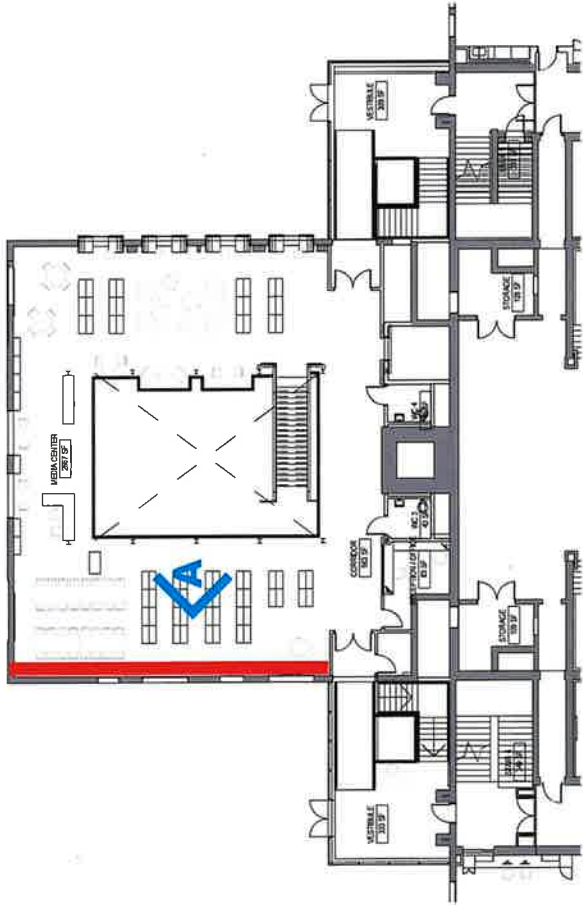

1

**ART LOCATION 2:**  
 EXISTING BRICK WALL ~70' LONG X 16' HIGH  
 AND (2) GARAGE DOORS  
**CONCEPT:**  
 LARGE SCALE MURAL. BOTH AREAS TO BE RELATED PIECES

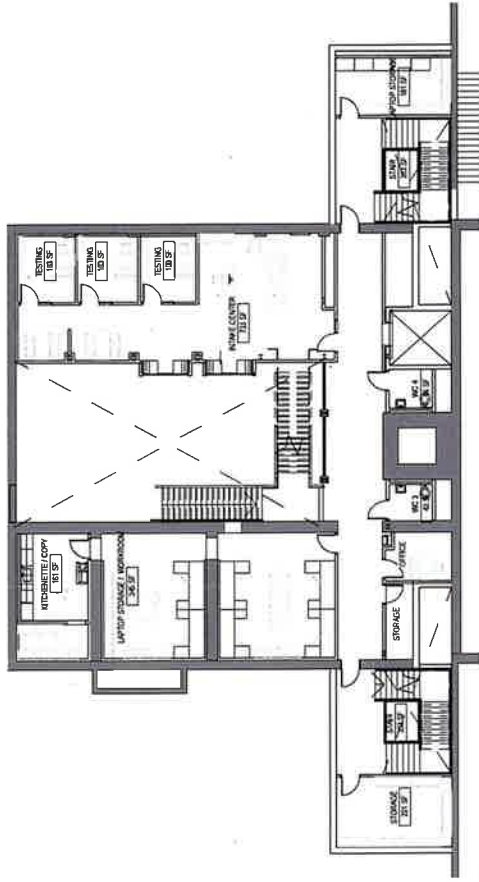

B1



B2

**ART LOCATION 2: MEDIA CENTER PLANS**  
 DGS - MACFARLAND MIDDLE SCHOOL

November 2017

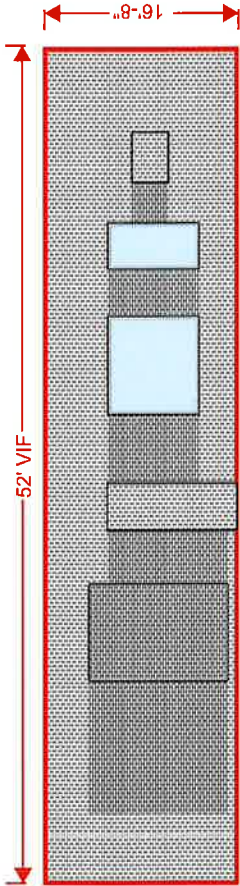

**ELEVATION A:**

BRICK WALL, PAINTED WHITE WITH (3) BRICK INFILL LOCATIONS AND (2) WINDOWS

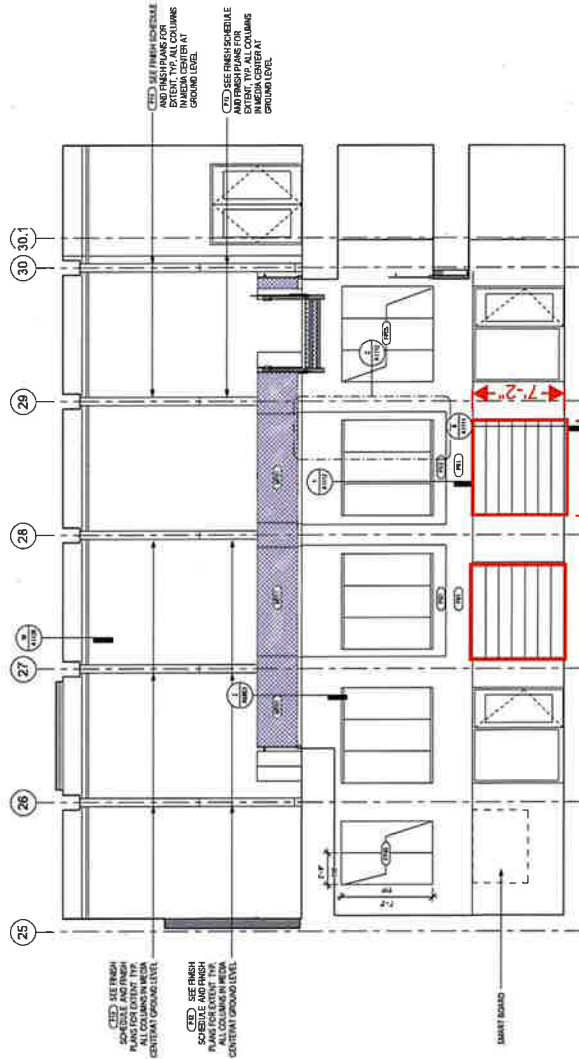

**ELEVATION B: (2) METAL GARAGE DOORS**

\*NOTE: ALL DIMENSIONS TO BE VERIFIED IN FIELD

**ART LOCATION 2: MEDIA CENTER ELEVATIONS**  
**DGS - MACFARLAND MIDDLE SCHOOL**

October 2017

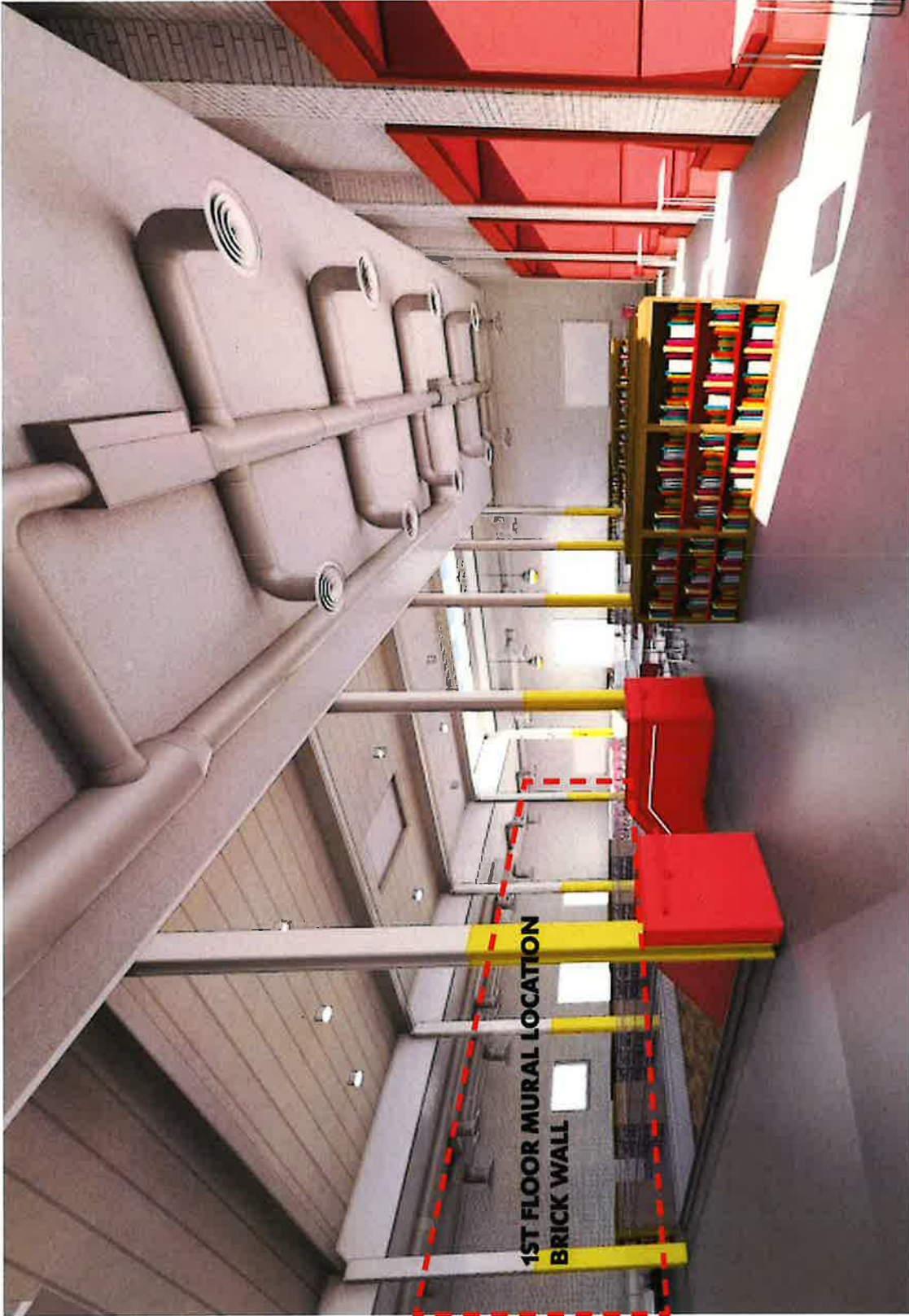

1ST FLOOR MURAL LOCATION  
BRICK WALL

**ART LOCATION 2: MEDIA CENTER - RENDERING**  
**DGS - MACFARLAND MIDDLE SCHOOL**

November 2017



**B2 MURAL LOCATION  
(2) GARAGE DOORS**

**ART LOCATION 2: MEDIA CENTER - RENDERING  
DGS - MACFARLAND MIDDLE SCHOOL**

November 2017





**ART LOCATION 2: MEDIA CENTER - MURAL CONCEPT IMAGES**  
**DGS - MACFARLAND MIDDLE SCHOOL**

November 2017

**ART LOCATION 3:**  
NEW ENTRY VESTIBULES, ABOVE STAIRS  
**CONCEPT:**  
SUSPENDED ART PIECE

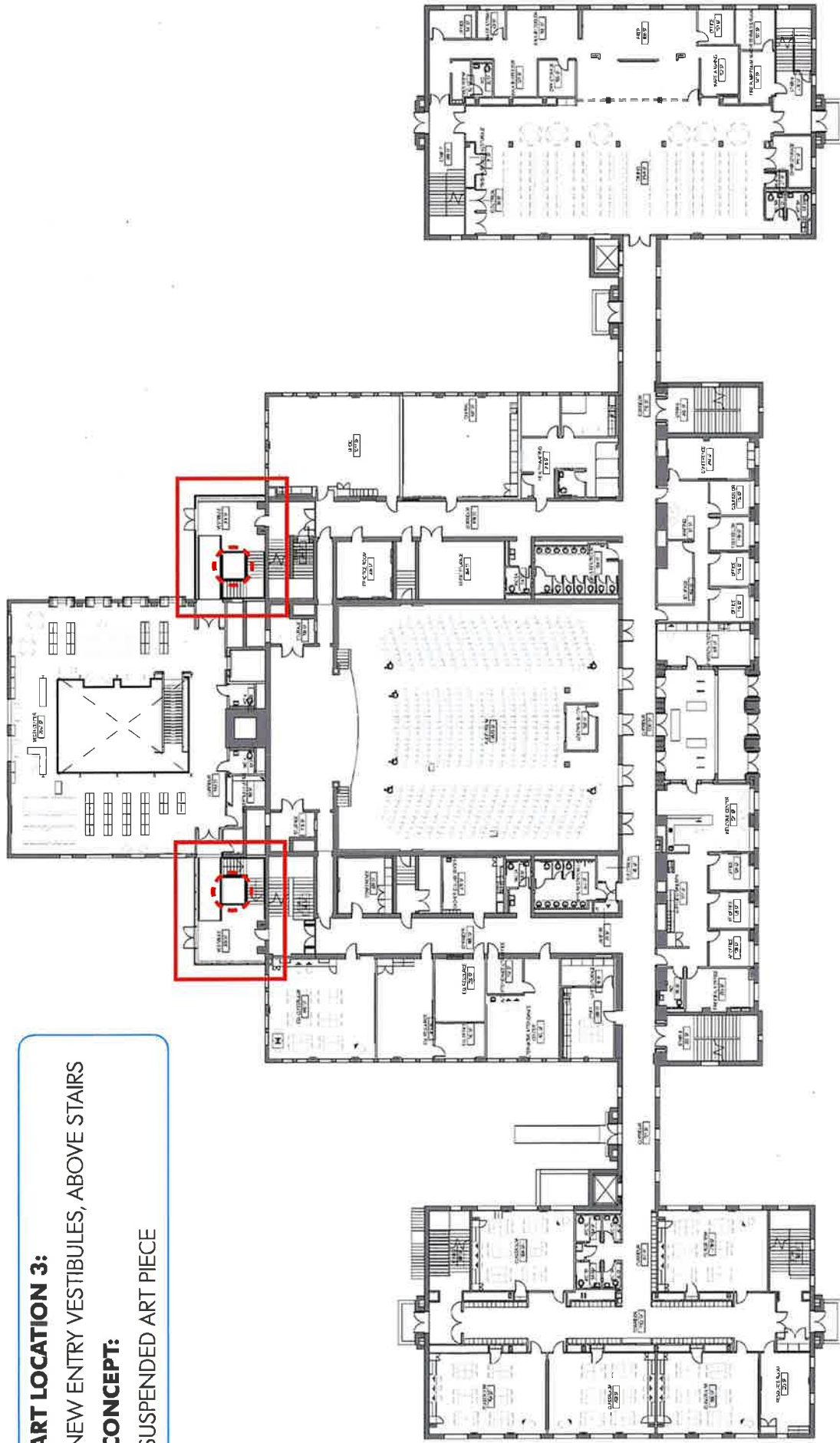

**ART LOCATION 3: FIRST FLOOR PLAN**  
DGS - MACFARLAND MIDDLE SCHOOL  
November 2017

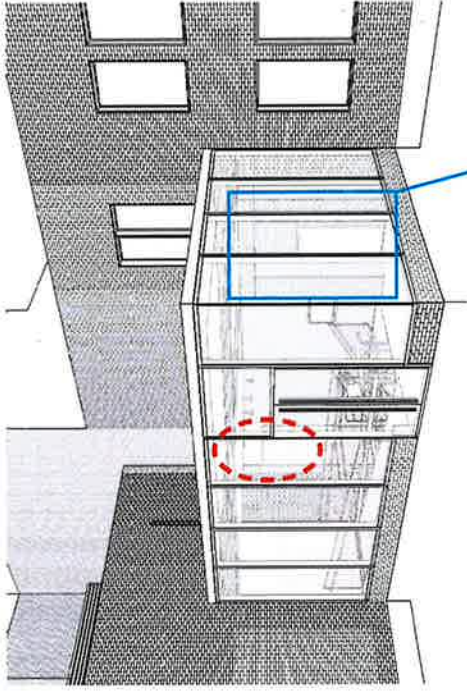

Existing brick and stone portal to be maintained.

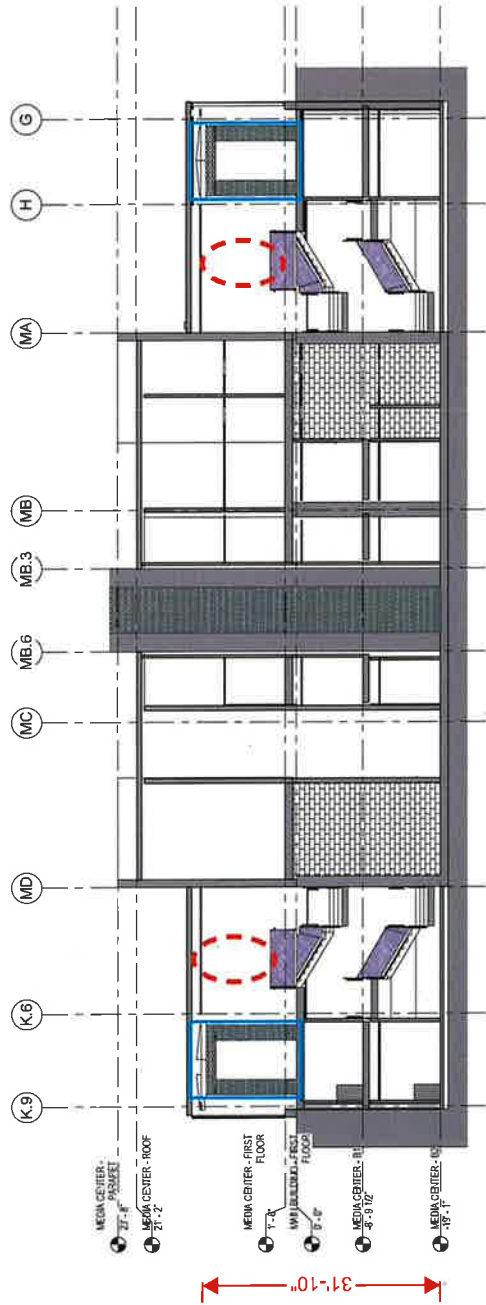
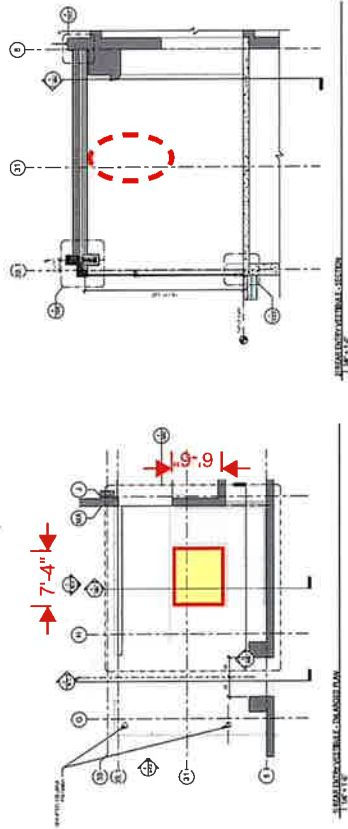

**\*NOTE: ALL DIMENSIONS TO BE VERIFIED IN FIELD**  
**ART LOCATION 3: PLANS, SECTIONS AND AXON**  
**DGS - MACFARLAND MIDDLE SCHOOL**

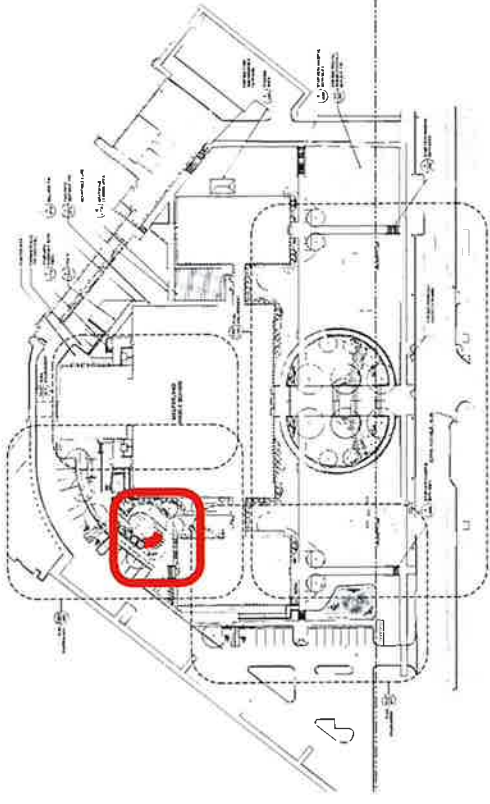
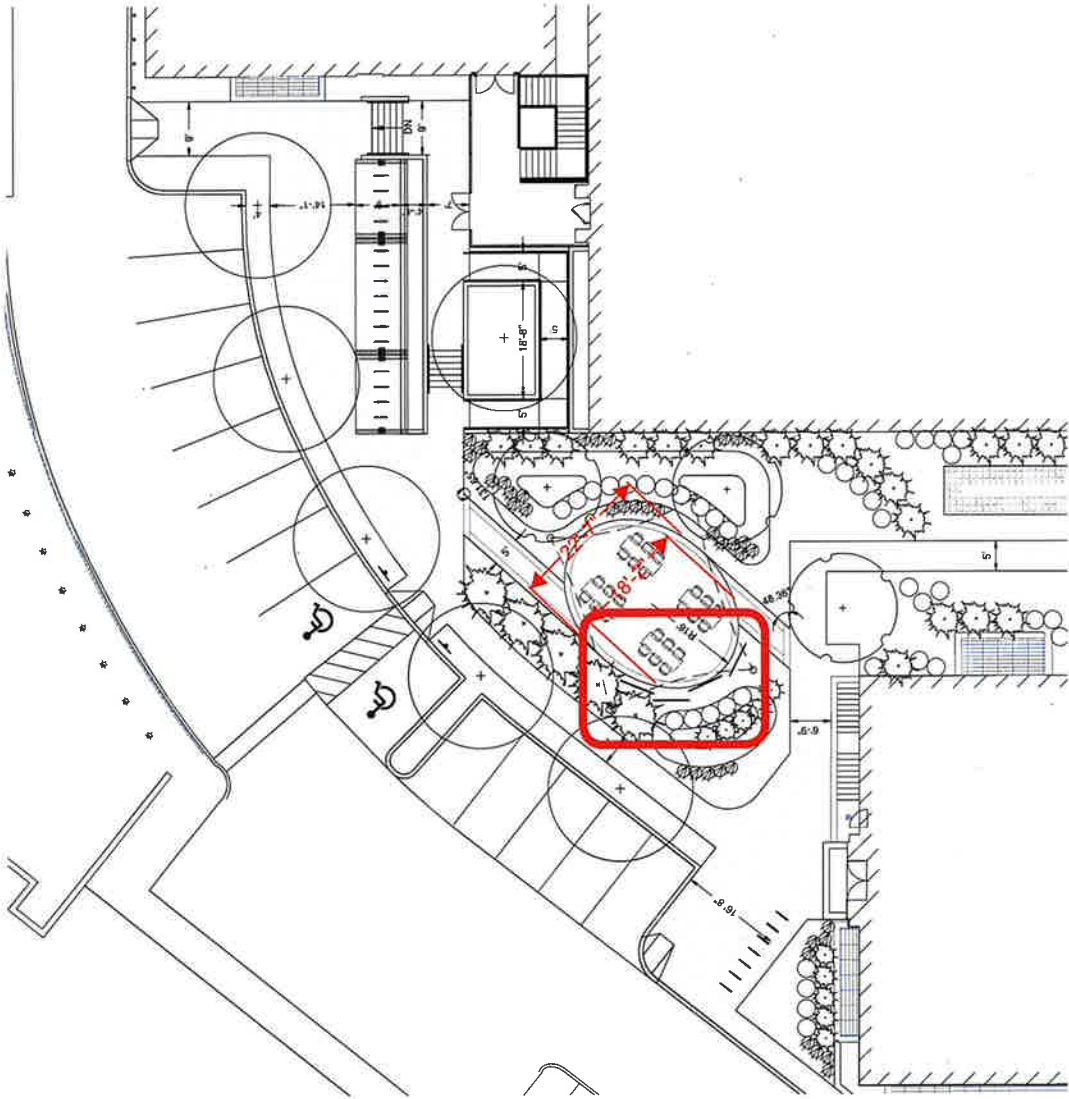

**ART LOCATION 4:**  
 OUTDOOR CLASSROOM, SIZE TBD  
**CONCEPT:**  
 DECORATIVE PRIVACY WITH ABILITY TO ATTACH PORTABLE  
 BLACKBOARDS

\*NOTE: ALL DIMENSIONS TO BE VERIFIED IN FIELD

**ART LOCATION 4: OUTDOOR CLASSROOM - PLAN**  
 DGS - MACFARLAND MIDDLE SCHOOL

October 2017

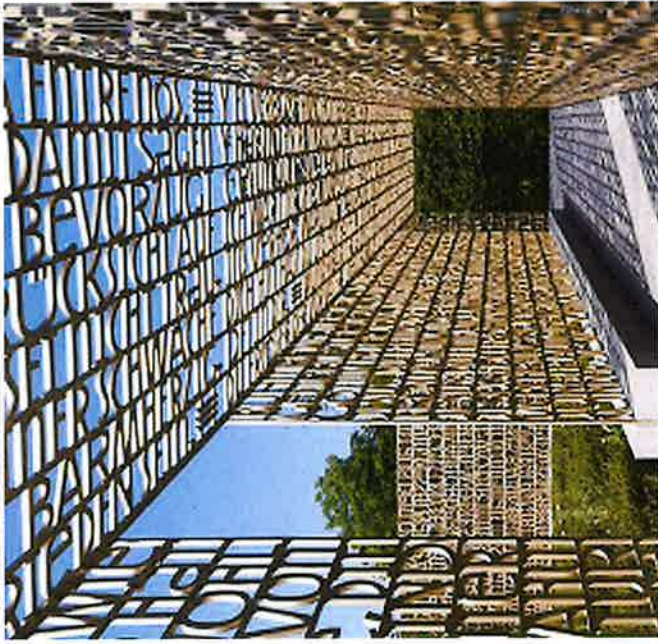
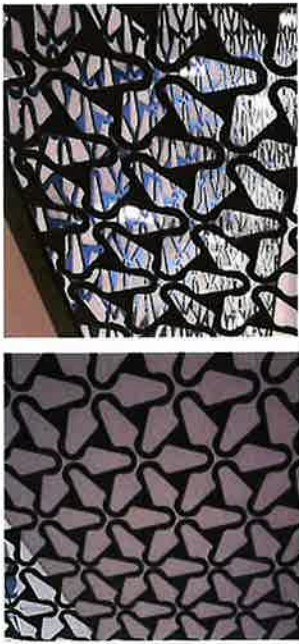

BASI

ORNAMENTAL PANELS

BASIS OF DESIGN: PARASOLEI OR SIMILAR

**ART LOCATION 4: OUTDOOR CLASSROOM - DECORATIVE SCREEN**  
**DGS - MACFARLAND MIDDLE SCHOOL.**

November 2017

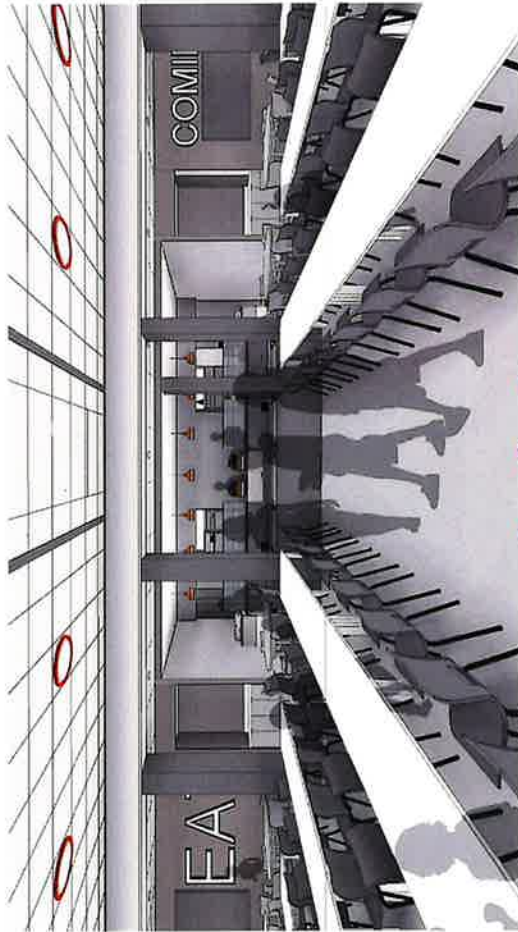

\*NOTE: ART CAN ONLY PROJECT 4" OFF THE WALL MAXIMUM.

10' 10'

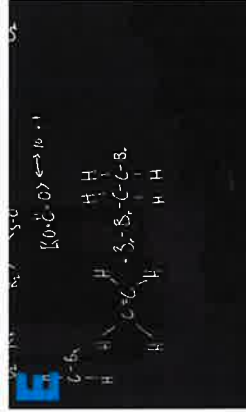
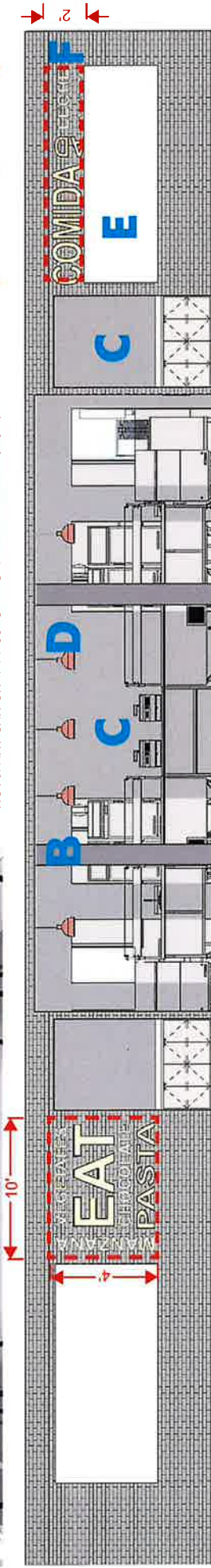

\*NOTE: ALL DIMENSIONS TO BE VERIFIED IN FIELD

**ART LOCATION 5: CAFETERIA - FEATURE WALL**  
**DGS - MACFARLAND MIDDLE SCHOOL**

October 2017

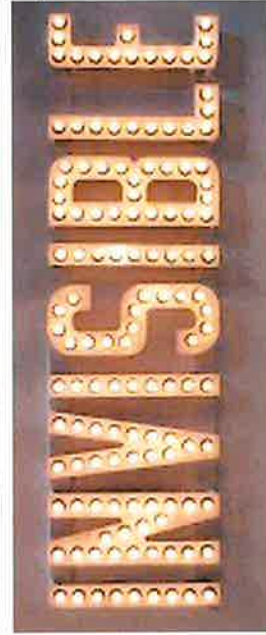
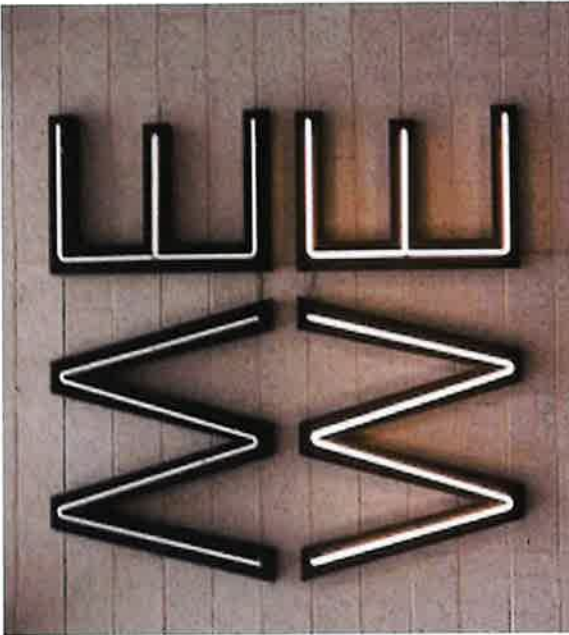
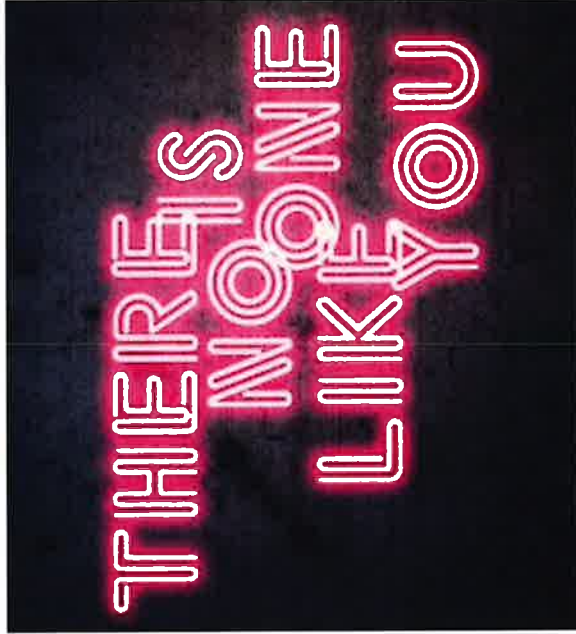

ART LOCATION 5: CAFETERIA - WORD, LIGHT CONCEPT IMAGES  
DGS - MACFARLAND MIDDLE SCHOOL

November 2017

**ART LOCATION 6:**

WALL MURAL AT EXISTING BRICK WALL

**CONCEPT:**

PERFORMING ARTS THEMED MURAL



**ART LOCATION 6: FIRST FLOOR PLAN**  
**DGS - MACFARLAND MIDDLE SCHOOL**

November 2017



**ART LOCATION 7:**

WALL MURAL AT EXISTING BRICK WALL

**CONCEPT:**

SCIENCE THEMED MURAL

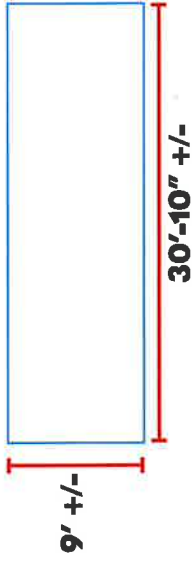
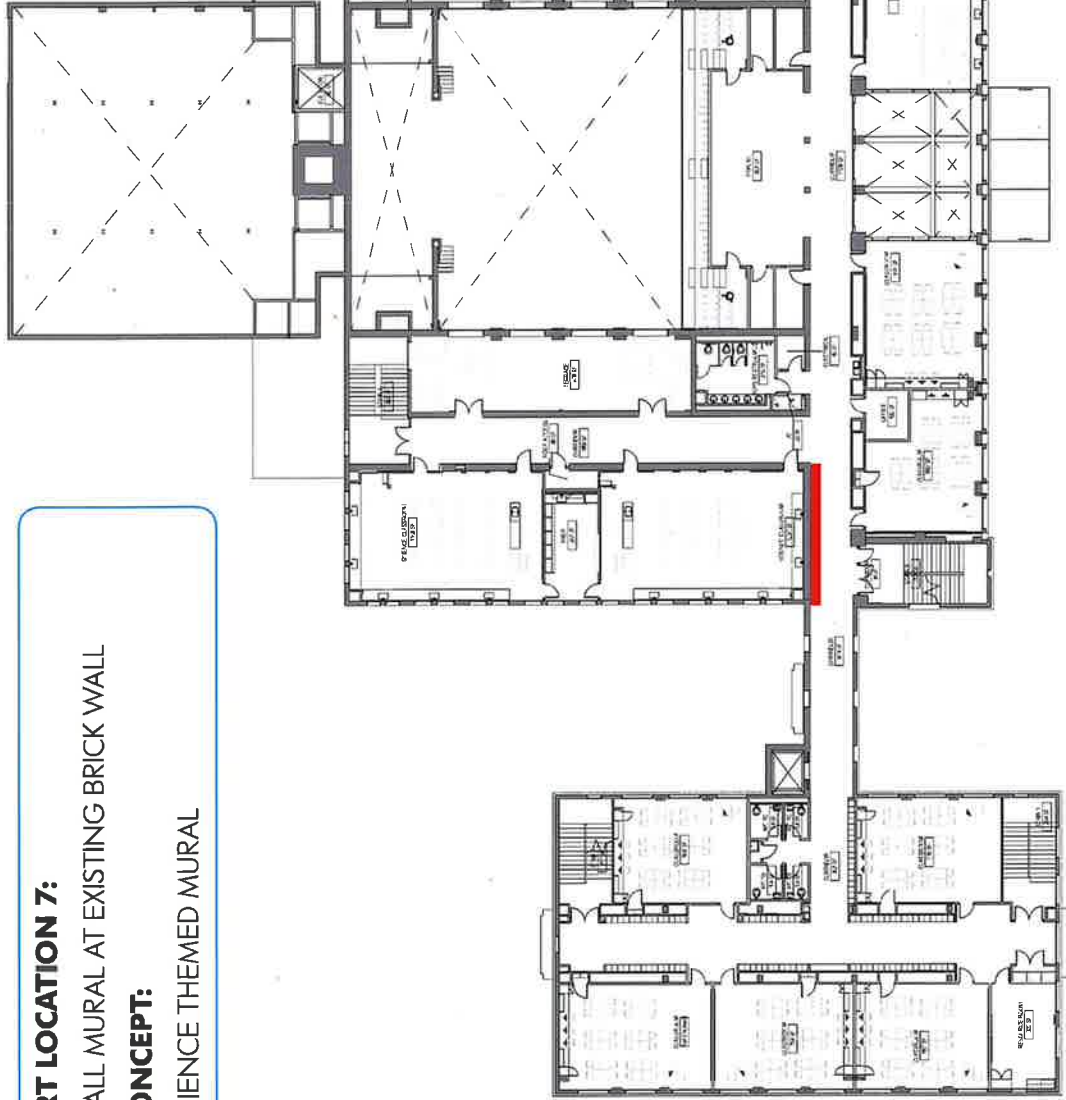

**ART LOCATION 8:**

WALL MURAL AT EXISTING BRICK WALL

**CONCEPT:**

VISUAL ARTS THEMED MURAL

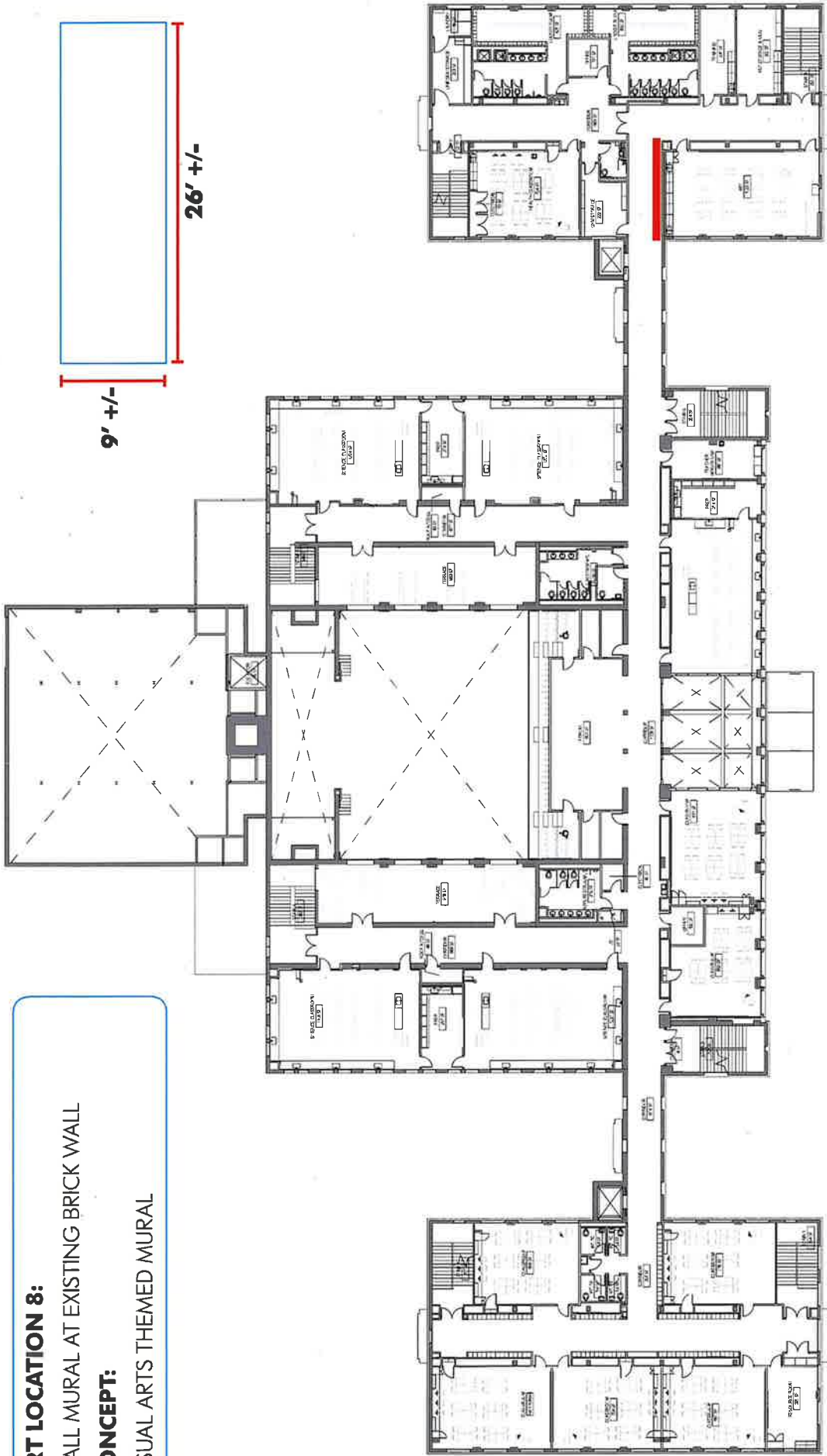

**ART LOCATION 8: SECOND FLOOR PLAN**  
**DGS - MACFARLAND MIDDLE SCHOOL**

November 2017